

# 2025 HVDC IMPACT ASSESSMENT



December 2025

## HIGHLIGHTS

- Multiple factors, including the increase in renewable generation, economics, and merchant-based HVDC transmission projects, are driving MISO's need to understand impact and identify work required to incorporate planned and future facilities into MISO's planning, operations, and markets.
- This impact assessment has several focus areas aligned with MISO stakeholder-informed key questions, including markets, reliability operations, resource adequacy, interconnection of merchant HVDC, and expansion planning of intraregional lines.
- Based on the impact assessment, recommendations of future work are identified. These will be prioritized alongside non-HVDC work items when updating MISO's roadmap.



[misoenergy.org](http://misoenergy.org)



# Table of Contents

TABLE OF CONTENTS .....	2
PREFACE .....	3
EXECUTIVE SUMMARY .....	4
1 BACKGROUND .....	13
2 MARKET IMPACT ASSESSMENT .....	16
3 RELIABILITY OPERATIONS IMPACT ASSESSMENT.....	28
4 RESOURCE ADEQUACY IMPACT ASSESSMENT.....	39
5 INTERCONNECTION OF MERCHANT HVDC LINES.....	47
6 TRANSMISSION EXPANSION PLANNING OF INTRA-REGIONAL HVDC LINES.....	50
7 FUTURE WORK.....	66
8 ACRONYMS AND GLOSSARY .....	68
9 TECHNICAL APPENDIX .....	73



# Preface

The electric power sector is experiencing unprecedented changes. Renewable resources represent an increasing portion of the generation portfolio, necessitating greater amounts of energy to be transmitted over longer distances than in the past. Demand is rising faster than it has in decades, driven by data centers and computing loads, electrification, and advanced manufacturing. At the same time, aging traditional “baseload” generation resources are facing retirement, while new dispatchable resources require long lead times for construction.

Utilities and grid operators are exploring ways to meet energy adequacy and reliability obligations, leveraging new technologies like storage and innovative solutions such as demand response programs. One of these alternatives, merchant High Voltage Direct Current (HVDC), is being proposed to increase transfer capabilities, given HVDC’s ability to support long-distance transfer, flow control, and ancillary service benefits. MISO is seeing interest in both merchant-led and regionally planned HVDC projects. MISO’s Merchant HVDC (MHVDC) Interconnection Queue currently contains three projects – North Plains Connector, Grain Belt Express, and SOO Green – with planned commercial operation in the 2030-32 timeframe. In parallel, utility-led, non-merchant HVDC projects are advancing. For example, Minnesota Power is modernizing the Square Butte HVDC line to incorporate voltage source converter (VSC) technology, enhancing controllability and grid support capabilities within MISO’s footprint.

MISO and its stakeholders recognize the opportunities HVDC brings and its cross-cutting impact on all four of MISO’s [Reliability Imperative](#) pillars: Market Redefinition, Operations of the Future, System Enhancements, and future Transmission Evolution. Stakeholders have requested MISO prioritize initiatives related to HVDC facilities, as reflected in the MISO Dashboard issues [MSC-2024-8](#) (Incorporating HVDC in Energy and Ancillary Services Market Operations, as well as Transmission Planning) and [RASC-2024-5](#) (Capacity Accreditation for External Resources facilitated by HVDC Transmission).

This paper presents an impact assessment of HVDC and provides initial recommendations for future work across MISO’s markets, reliability operations, resource adequacy, and planning organizations. Each section of the assessment briefly examines current practices, summarizes the analyses performed to understand HVDC impacts, and highlights key recommendations stemming from assessment insights.



# Executive Summary

High Voltage Direct Current (HVDC) transmission spans all four of MISO's Reliability Imperative pillars: Market Redefinition, Operations of the Future, System Enhancements, and Transmission Evolution. Increasing renewable generation, economic factors, and merchant-based HVDC transmission projects are driving the need for MISO to understand the impact across those pillars and identify work necessary to incorporate planned and future facilities into MISO's planning, operations, and markets.

Figure 1 illustrates the volume and region of proposed HVDC across the United States and Canada as of November 2024. Within MISO, there are currently several operational HVDC facilities: Coal Creek to Dickinson (noted as CU in the figure), Square Butte – Arrowhead, Manitoba Hydro Forbes/Nelson River Bipoles I, II and III; and Mackinac back-to-back. Proposed HVDC lines to be connected to MISO include the merchant HVDC projects Grain Belt Express, Southern Spirit (application withdrawn), North Plains Connector, SOO Green, and an upgrade to the Square Butte – Arrowhead facility.

HVDC stakeholders have requested MISO prioritize initiatives related to HVDC facilities, as reflected in the MISO Dashboard issues [MSC-2024-8](#) (Incorporating HVDC in Energy and Ancillary Services Market Operations, as well as Transmission Planning) and [RASC-2024-5](#) (Capacity Accreditation for External Resources facilitated by HVDC Transmission). During the April 29, 2025, [HVDC Assessment Workshop](#), MISO and stakeholders identified key questions to define the focus areas for the 2025 impact assessment.

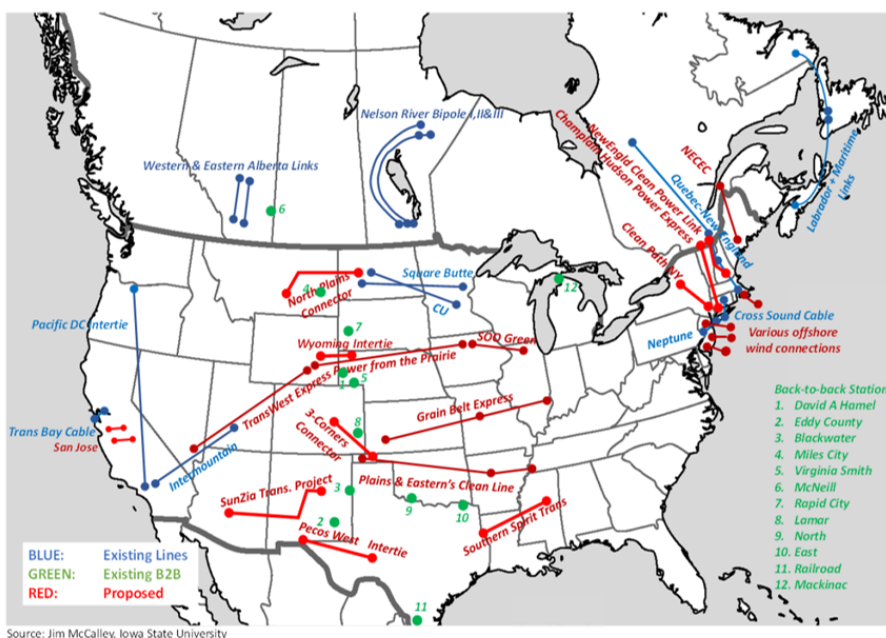

Ref: MISO HVDC Analysis Process for MTEP and LRTP, OMS MHVDC Workshop, April 2024  
Updated November 2024

Used with permission from Dr. McCallev, Iowa State University

**Figure 1: Existing and Planned HVDC in the United States and Canada**



This paper describes the HVDC impact assessment and provides recommendations for future work across markets, reliability operations, resource adequacy, and planning. Each section briefly examines current practices, summarizes the analyses performed to understand HVDC impacts, and highlights key recommendations stemming from assessment insights. HVDC recommendations will be considered alongside other non-HVDC work items when updating MISO's Roadmap.

While the HVDC recommendations are not time-bound, they reflect three levels of priority. Recommendations beginning with:

- “MISO should” are high priority relative to other HVDC recommendations. These actions address reliability concerns or stakeholder priority.
- “As HVDC penetration increases, MISO should” are medium priority relative to other HVDC recommendations, with the need linked to further deployment of HVDC facilities within MISO. These actions can wait until planned HVDC facilities advance further in their development.
- “MISO could” are lower priority. These represent issues and ideas identified during MISO's assessment that might have value but are not necessarily pressing.

## MARKETS

MISO currently supports three HVDC participation models: generation lead lines, manually scheduled reliability assets, and external asynchronous resources (EARs). These models were developed on a case-by-case basis to address specific operational needs and do not constitute a unified framework for dispatchable HVDC integration. All existing HVDC facilities either operate within MISO's footprint or connect to asynchronous systems, such as Manitoba Hydro. MISO has no precedent for dispatchable HVDC connecting its system to synchronized, market-based neighbors like PJM or SPP.

### INTRA-REGIONAL HVDC OPTIMIZATION

In principle, HVDC flows could be co-optimized with generation and load in MISO's market systems. MISO presented initial conceptual formulations 2021 and subsequently collaborated with the National Laboratory of the Rockies (NLR)<sup>1</sup> to conduct simulations, which performed well under positive pricing but revealed challenges such as circular flows and loss-maximizing behavior under negative prices.

#### Other RTOs have addressed similar challenges:

- As a transmission asset under CAISO's operational control, the Trans Bay Cable is integrated into 5-minute Security Constrained Economic Dispatch (SCED), although HVDC losses are not modeled explicitly.
- NYISO's proposed approach excludes internal controllable lines from TCC (Transmission Congestion Contract) markets to maintain dispatch flexibility.

MISO will continue collaborating with NLR to develop constraints that prevent circular flows and to evaluate alternative approaches for modeling HVDC losses.

---

<sup>1</sup> MISO is collaborating with NLR on a range of research initiatives, including HVDC modeling, market integration, and the development of interregional coordination frameworks.



## INTERREGIONAL HVDC COORDINATION AND RESOURCE PARTICIPATION

Currently two interregional coordination processes are active in MISO. The Market-to-Market (M2M) process facilitates coordination between MISO and neighboring markets to manage congestion on AC flowgates impacted by both markets in a cost-effective manner. The Coordinated Transaction Scheduling (CTS) process is designed to support cost-reducing interchange transactions<sup>2</sup> that reflect real-time price differences between markets. These processes were developed with non-controllable AC networks in mind.

Interregional coordination processes could be enhanced to identify opportunities for real-time congestion relief and more efficient interchange through controllable HVDC. These processes could evolve through graduated approaches tailored to dispatch authority, operational goals, and the participation of external resources enabled by HVDC. How these resources participate in MISO's markets (e.g., via pseudo-tie or EAR models) would depend on the coordination approach and project-specific characteristics. The following three approaches reflect a progression from status quo toward increasing levels of coordination and complexity.

Level 0 HVDC Owner Operates the Line (Status quo)	Level 1 Single RTO Dispatches for M2M Congestion Relief	Level 2 Dynamic Interchange Optimization
<p>The HVDC owner independently dispatches the line with no control from MISO or neighboring RTOs. HVDC flows are treated as fixed interchange and excluded from economic redispatch in both markets, with M2M continuing to identify generation redispatch solutions for congestion management. If HVDC contributes to congestion and generation relief is insufficient, only reliability-based curtailment remains.</p>	<p>One of the RTOs dispatches HVDC for internal optimization and for M2M congestion relief. This may require coordinating neighbors to exchange additional information beyond the shadow prices currently exchanged. Sharing relief cost curves, HVDC availability, ramp rates, and real-time congestion relief potential may be necessary to fully leverage HVDC controllability in M2M coordination.</p>	<p>One of the RTOs dispatches the HVDC line to vary interchange schedules across intervals (in contrast to Level 1, where net interchange is fixed). This requires both RTOs to coordinate on interchange accounting and power balancing, as HVDC flows directly affect power balance and transmission constraints in both systems. This approach offers flexibility but introduces additional operational complexity.</p>

## RECOMMENDATIONS

This assessment identifies three areas for potential enhancement to support efficient integration of HVDC into MISO's markets:

### 1. Interchange and market-to-market congestion management processes

Under current interchange and M2M coordination processes, large interregional HVDC facilities could complicate balancing and AC congestion management. While interchange schedules that threaten reliability can be interrupted using the Transmission Loading Relief (TLR) process, such interruptions are costly. Enhancing interchange and market-to-market coordination processes to

<sup>2</sup> Most interregional transactions are scheduled by market participants via e-Tags. While essential, these do not provide the operator-level coordination described here.



explicitly account for HVDC would allow these facilities to be controlled or incentivized to cost effectively mitigate energy imbalances and AC congestion, rather than exacerbating them.

*As penetration of HVDC increases, MISO should evaluate approaches to integrate HVDC into interchange and market-to-market congestion management processes and discuss these approaches with neighboring RTOs.*

## 2. Intra-regional HVDC in market and operations processes

Under current market and operations processes, intra-regional HVDC facilities are generally not scheduled by MISO and can exacerbate AC system congestion. Integrating HVDC scheduling into dispatch and commitment processes would allow MISO to use these facilities to manage congestion rather than worsen it. Full integration is complicated by the potential for fully optimized HVDC schedules to drive circular flows, large angle differences between buses, swings in AC loss factors, unphysical bi-directional modeled flows, and increased overall losses.

Near-term implementation could leverage CAISO's operational experience with five-minute dispatch, as well as NYISO's proposed framework for treating controllable lines as resources. *As HVDC penetration increases, MISO should evaluate these potential approaches to partially integrate intra-regional HVDC into market and operations practices. Additionally, MISO could continue researching open questions related to full integration.*

## 3. HVDC in congestion hedging processes

HVDC schedules in the FTR auctions impact the simultaneously feasible FTRs that can be cleared. When HVDC schedules differ between the FTR auctions and the day-ahead market under substantially similar conditions, auction-cleared FTRs may not be simultaneously feasible in day-ahead, potentially leading to underfunding. Additionally, inflexible scheduling of HVDC in the FTR auctions may reduce hedging opportunities. These challenges are compounded by the variety of approaches currently used to schedule HVDC facilities in day-ahead and real-time markets.

*MISO could assess the risk of FTR underfunding and potential missed hedging opportunities and evaluate process enhancements to better align FTR auctions with evolving operational practices.* Implementation approach and timing would depend on project characteristics, agreements with neighboring RTOs, regulatory direction, and stakeholder engagement outcomes.

## RELIABILITY OPERATIONS

VSC-based HVDC technology<sup>3</sup> can play an important role in enhancing system stability. It can provide fast and precise power flow control, helping to reduce bus phase angle separation during disturbances and supporting voltage in weak grid areas. Additionally, it can contribute to inertia-like responses and oscillation damping.

However, as these systems become more widespread and interact with Inverter-Based Resources (IBRs) and other advanced controls, new converter-driven and resonance stability risks may emerge. The net

---

<sup>3</sup> The reliability assessment focuses on the impacts of Voltage Source Converter (VSC)-based HVDC systems. While the background section of this document discusses multiple HVDC technologies, VSC systems are emphasized due to their prominence in current HVDC proposals across MISO's footprint.



stability benefit of HVDC therefore depends on the availability of appropriate technology, proper control tuning, and continuous coordination with real-time operations.

Figure 2 provides a conceptual representation of stability benefits and risks associated with VSC-based HVDC technology.

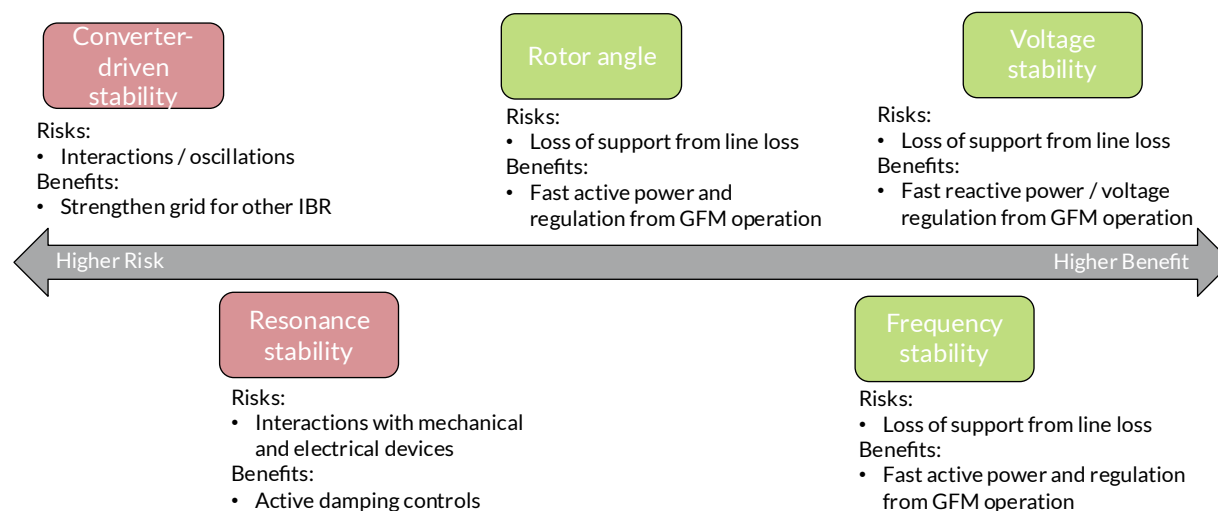

Figure 2: Conceptual representation of the risks and benefits of VSC-HVDC on various aspects of system stability

As described in the [Market Impact Assessment](#) section, MISO uses three types of HVDC models, developed on a case-by-case basis, to meet specific operational needs. These models support various real-time analysis functions in the Energy Management System (EMS). The way an HVDC system is modeled directly affects the data that must be delivered via Supervisory Control and Data Acquisition (SCADA). Under current practices, SCADA does not include dedicated DC-side alarms, and many models simplify or omit HVDC controllability and loss characteristics. This limits operator visibility into HVDC interactions with the broader grid. As HVDC penetration increases, the grid will require enhanced representation of HVDC facilities within MISO's EMS, along with other enhancements to improve operator visibility.

Contingencies involving large HVDC lines can create disproportionate impacts due to the sudden and significant loss of power transfer. When a line trips offline, system frequency declines rapidly, with the Rate of Change of Frequency (RoCoF) depending on the outage magnitude and available inertia. In lower-inertia conditions, this can trigger widespread IBR tripping, Underfrequency Load Shedding (UFLS), and immediate activation of operating reserves. The loss of an HVDC line can create large shifts in power flow across tie lines and constrained interfaces, potentially causing thermal overloads and dynamic stability risks. Deliverability of contingency reserves becomes critical, particularly when reserve-sharing arrangements across Balancing Authorities are limited.

The current outage coordination process, outlined in [Business Practice Manual \(BPM\)-008](#), provides a robust framework for planning, analyzing, and managing transmission and generation outages using tools such as the Control Room Operations Window (CROW) and Available Flowgate Capability (AFC) evaluations. However, HVDC systems involve converter stations, DC cables, and reactive support



equipment, each of which may require maintenance or experience partial outages and must be mapped into existing outage categories. Outage coordination should increasingly incorporate stability assessments, as HVDC outages can cause high magnitude, complex impacts beyond thermal constraints.

## RECOMMENDATIONS

Following the reliability impact assessment and gap analysis, MISO has identified potential next steps:

### 1. Contingency management procedures for HVDC facilities

Due to the large size of some of the HVDC facilities being considered in the MISO region, the potential loss of one of these facilities could have significant impacts. The loss could become the Most Severe Single Contingency (MSSC) for the MISO region, increasing contingency reserve requirements, which would have associated cost impacts. *MISO should continue to update the MSSC and contingency reserve requirements as system conditions evolve to ensure reliability. As HVDC penetration increases, MISO should assess the risk of contingency reserve cost increases and evaluate opportunities to mitigate these impacts through reserve sharing agreements or alternative cost allocation processes.*

### 2. HVDC impacts on system stability risk

The sudden loss of a large HVDC facility could affect frequency, voltage, and rotor angle stability. Additionally, like other inverter-based facilities, power electronic controllers on the HVDC facility may contribute to oscillations. *As penetration of HVDC facilities increases, MISO should conduct, or coordinate with other entities to conduct, frequency, voltage, and rotor angle stability risk assessments related to HVDC facility losses, including evaluations of converter-driven stability risks.*

### 3. Outage coordination and operator visibility for HVDC facilities

HVDC facilities currently operating in MISO participate in both outage coordination and real-time operations processes. However, participation could be enhanced in several ways. *As penetration of HVDC facilities increases, MISO should evaluate more granular representation of de-rates during outage coordination processes, enhance the representation of HVDC facilities in the Energy Management System, and consider other improvements to improve operator visibility.*

## RESOURCE ADEQUACY

Several merchant HVDC transmission lines are being proposed for interconnection to the MISO transmission system. MISO has had numerous discussions with stakeholders regarding the increased interregional transfer capability that the new HVDC transmission could provide, and how this capability may contribute to reliability and help relieve pressure on planning requirements. Stakeholders have sought guidance on the treatment and potential accreditation of these HVDC transmission lines within MISO's resource adequacy construct which will help inform future investment decisions.

Through these discussions, MISO has communicated that incorporating HVDC into existing resource adequacy processes, or developing new processes, cannot occur in isolation from a holistic assessment of overall HVDC integration. MISO acknowledges the need for stakeholder confidence prior to advancing HVDC transmission proposals, which is why MISO is providing this framework to guide evaluation of potential changes to the resource adequacy construct.



MISO has considered several mechanisms to incorporate HVDC transmission into the resource adequacy construct, provided here for discussion. Many of the potential solutions could require significant changes to MISO's Loss of Load Expectation (LOLE) modeling, as well as coordination and agreements with neighboring regions.

## RECOMMENDATIONS

MISO is committed to continuing work in this area and offers the following recommendations:

### 1. Resource adequacy treatment of external resources, including those delivered via HVDC

Under the current resource adequacy construct, External Resources can earn accreditation in the Planning Resource Auction (PRA) by demonstrating a firm contractual right to capacity and firm transmission to the MISO border and from the border to an identified MISO sink. These existing mechanisms allow HVDC-enabled external resources to participate directly in the PRA. However, stakeholders have conveyed that this process lacks sufficient clarity.

*MISO should collaborate with stakeholders to clarify how external resources, including those delivered by HVDC-enabled firm transmission, are modeled and participate under MISO's current resource adequacy construct.*

### 2. Accreditation enhancements for external resources

Accreditation of external resources has not yet been aligned with the Direct Loss of Load/Resource Adequacy hours framework that will apply to internal resources beginning in Planning Year 2028/29.

*MISO should evaluate updates to external resource accreditation to improve alignment with the Direct Loss of Load/resource adequacy hours approach.*

### 3. Representation of transmission in resource adequacy risk modeling

MISO's resource adequacy risk model is used to determine the system-wide Planning Reserve Margin Requirements (PRMR), Local Reliability Requirements, and, in the future, the accreditation of resources. Today, this analysis is conducted without transmission modeled (a copper sheet).

*MISO could evaluate approaches to incorporating transmission, including HVDC facilities, into resource adequacy risk modeling.*

## INTERCONNECTION OF MERCHANT INTERREGIONAL (OR INTRA-REGIONAL) HVDC LINES

Merchant interregional HVDC projects are progressing through the MISO MHVDC queue. Realizing the commercial value of these projects depends on securing the appropriate commercial products and approvals, including injection and withdrawal rights, deliverability for capacity and market participation, Transmission Service Request (TSR) transactions, and, where applicable, clearly defined limited-operation conditions to support safe interim use.

Reliable integration of MHVDC projects requires disciplined modeling and coordinated execution across all parties involved, including RTOs/ISOs, interconnection customers, Transmission Owners, and neighboring systems.



## RECOMMENDATIONS

Future work planned for MHVDC through the Interconnection Planning Working Group (IPWG) includes:

### 1. Improvements to the MISO Attachment GGG process

Stakeholders have requested greater clarity and streamlining of interconnection processes for HVDC facilities. These requests include the use of TSRs via Module B for injection and withdraw rights and the development of preliminary MHVDC study procedures to better service customers prior to the full Attachment GGG studies. *MISO is making Tariff revisions to Attachment GGG, updating the MISO MHVDC interconnection process, and clarifying limited-operation conditions for interim periods on qualified MHVDC projects. MISO will continue engaging with stakeholders on these topics through the IPWG and PAC.*

### 2. HVDC Business Practice Manual

Stakeholders have requested that MISO develop a dedicated BPM to enhance clarity, efficiency, and alignment with Tariff requirements for the MHVDC interconnection process. *MISO is creating an HVDC BPM that will address MHVDC applications, application modifications and withdrawals, study scope and timelines, study requirements, affected system studies, and pre-TCA considerations.*

## TRANSMISSION EXPANSION PLANNING OF INTRA-REGIONAL HVDC LINES

From a regional planning perspective, MISO applies an “all things considered” strategy when evaluating transmission solutions, including legacy EHV AC (345 kV and 500 kV), 765 kV EHV AC, and HVDC options. MISO analysis shows that HVDC generally offers a lower cost-per-megawatt-mile for line lengths exceeding 400 miles, whereas EHV AC, particularly 765 kV, tends to have the lowest cost-per-megawatt-mile for lines shorter than 250 miles. For line lengths between 250 and 400 miles, HVDC versus EHV AC must be evaluated on a case-by-case basis.

HVDC provides granular flow control that can be advantageous in managing flows on parallel AC lines. Conversely, EHV AC’s natural flow response can be more effective for managing renewable variability and large load fluctuations. These trade-offs are further described in this white paper.

While Line-Commutated Converter (LCC) HVDC lines consume substantial reactive power, newer VSC HVDC lines provide dynamic reactive support, a potential benefit when nearby facilities (e.g., conventional synchronous machines or inverter-based generation resources) are not already available to supply sufficient dynamic reactive power. Therefore, the potential reactive power benefits of VSC HVDC must be evaluated on a case-by-case basis.

In addition, VSC HVDC converters are also grid forming, a potential benefit when nearby facilities (e.g., conventional synchronous machines and grid forming inverter-based generation resources) are not already in place and capable of supplying these grid forming benefits. Therefore, the potential grid-forming benefits of VSC HVDC must also be evaluated on a case-by-case basis.

HVDC may play an important role alongside EHV AC solutions in MISO’s future regional transmission system. However, any HVDC solutions selected through the regional planning process will need to either:

- Employ VSC technology, be dispatchable, and be co-optimized with resource outputs on a five-minute basis through the real-time SCED algorithm; or



- Be configured with controls that emulate an AC line using a proxy impedance not feasible for an AC line of comparable length.

## RECOMMENDATIONS

### 1. Test modeling and performance of PROMOD HVDC simulation capabilities

HVDC may play a role alongside EHV AC solutions in MISO's future regional transmission system. However, any HVDC solutions selected through the regional planning process will need appropriate modeling and control capabilities. *As a medium priority, MISO should test the modeling and performance of the dispatchable and co-optimized HVDC capability of PROMOD to ensure it is an acceptable proxy for the dispatchable HVDC solution to be developed by the market side.*

### 2. Investigate feasibility of AC line emulation controls

Some HVDC facilities can be configured to emulate the behavior of AC transmission facilities. *MISO could further investigate the feasibility of AC line-emulation controls as an option for future regional HVDC lines where AC response is desired, but the line length is too long for an AC line.*



# 1 Background

## STAKEHOLDER ENGAGEMENT

MISO Stakeholders have expressed interest in several focus areas related to HVDC.

For merchant HVDC lines, stakeholders are actively involved in MISO's ongoing work with Attachment GGG updates.

In expansion planning, prior discussions have been conducted with stakeholder involvement. On February 16, 2021, MISO held a stakeholder workshop titled "New Ideas, Approaches, and Technologies to be considered in Planning for a Renewable Heavy Market." MISO and external entities made several presentations on HVDC, including one titled "Market Dispatchable HVDC." MISO has also presented topics on HVDC at the PAC, one at the March 8, 2023, PAC meeting titled "Discussion of 765 kV and HVDC," and a second at the May 2023 PAC, which included an extra day to allow external entities to make HVDC presentations to the PAC.

In markets, MISO and stakeholders have established MISO dashboard issue [MSC-2024-8](#) (Incorporating HVDC in Energy and Ancillary Services Market Operations, as well as Transmission Planning) and [RASC-2024-5](#) (Capacity Accreditation for External Resources facilitated by HVDC Transmission).

Stakeholders were involved in defining the focus areas for this impact assessment document through the [HVDC Assessment Workshop](#) on April 29, 2025 and via [Stakeholder Feedback](#) following that workshop. This assessment addresses stakeholder feedback, outlining the scope of HVDC impacts on MISO planning, operations, and markets and provides recommendations for additional work. A summary of this impact assessment will be presented at the [HVDC Assessment Workshop](#) on December 16, 2025, to be followed with a request for feedback to be submitted by February 2026.

## CONTINUED STAKEHOLDER INPUT IS CRUCIAL

Many ideas in this document reflect input from MISO stakeholders. MISO appreciates stakeholder feedback on this assessment and looks forward to continuing the dialogue with future work.

## HVDC TECHNOLOGY

Multiple HVDC voltage conversion transmission technologies have been considered to operationalize HVDC lines, including motor-generator sets, mercury arc technology, LCC technology, and most recently, voltage source converter (VSC) technology. LCC and VSC technology are solid state technologies and are primarily the technologies being considered for new HVDC transmission lines today. Except for the back-to-back HVDC link installed between Michigan's upper and lower peninsulas, all HVDC lines currently deployed within MISO's footprint are LCC technology. Minnesota Power's HVDC Modernization Project will bring HVDC VSC technology to MISO's footprint by 2030, between a new Nelson Lake substation in North Dakota and a new Saint Louis County Substation in Minnesota.

LCC technology uses thyristors to convert AC waveforms into DC voltages and vice versa. Thyristors are solid state switches that can be switched on by adjusting the firing angle at a precise point in the AC waveform when the device is forward-biased (i.e., when the converter has positive voltage across its



terminals). However, unlike fully controllable switches, thyristors cannot be turned off by control signals. Instead, they rely on the natural behavior of the AC waveform to cease conduction. This process, referred to as natural commutation, occurs automatically every half cycle of the AC voltage. As the AC current reverses direction and reaches zero, the thyristor naturally turns off, allowing the next thyristor in sequence to conduct. This commutation mechanism fundamentally depends on a strong and undistorted AC voltage waveform.

Multiple issues exist with LCC technology. First, LCC converters at both terminals consume a great deal of reactive power to facilitate voltage conversion. Second, unlike synchronous machines, LCC technology cannot form AC voltage waveforms, so historically synchronous machines are required at or beyond each terminal of the HVDC line to form the voltages. Lastly, LCC-based HVDC lines simply transfer power, given that voltages already exist at both line terminals. Because external voltage waveform formation is needed, system strength becomes an issue and LCC HVDC line performance generally requires sufficient levels of system strength at each terminal.

Voltage Source Converter (VSC) technology is a newer technology, one more likely to be used in the future. VSC technology uses solid state switching devices like insulated gate bipolar transistors (IGBTs) to facilitate voltage conversion. These devices can be switched on and off at high frequencies. These switches are controlled using a pulse width modulation (PWM) technique, where pulse timing and width are varied to approximate a desired sinusoidal waveform. This enables the converter to generate a controllable AC voltage and current from a DC source, and vice versa. For this reason, active and reactive power can be controlled independently on the AC side of voltage source converters. Not only does this fully eliminate the reactive power consumption issue associated with LCC technology, but it also allows VSC converters to be used as a source of dynamic reactive power at each AC terminal even when zero active power flow is scheduled on the HVDC line. VSC converters are also grid forming devices: they form AC voltage waveforms just like synchronous machines and grid forming inverters (GFMs) that interconnect renewable and energy storage resources. This benefit is not available from LCC technology. Because of grid forming capabilities, a VSC-based HVDC line can facilitate black starting one asynchronous system from another asynchronous system, unlike an LCC-based HVDC line.

In addition to LCC and VSC types, the HVDC line and converter have different pole and topology configurations, which have varying costs and provide different ways to transmit power. The configurations such as monopole, bipole, and back-to-back arrangements determine how power is transmitted, how redundancy is provided, and how the system behaves during faults or maintenance. Similarly, HVDC topologies such as two-terminal or multi-terminal arrangements determine whether the system operates as a point-to-point or as a more complex DC network with multiple injections and withdrawal points. Additional details about HVDC configuration and topology are provided in the [Technical Appendix](#).

## EXAMPLES OF HVDC TYPE CONFIGURATIONS

The HVDC lines in MISO today are mostly scheduled by the transmission owners, and most were originally put in place as generation lead lines. Additional HVDC configurations in MISO are the back-to-back HVDC station connecting the upper and lower peninsulas of Michigan, and the Manitoba HVDC lines that connect the asynchronous northern Manitoba system to the south. The Manitoba lines are



modeled as an External Asynchronous Resource, allowing for market offer submissions that are co-optimized in SCED and receive dispatch targets. The MISO regionally planned HVDC lines are intra-regional lines (internal to MISO) that would be scheduled by MISO. The scheduling would be via either co-optimizing the line schedules with resource outputs via the Security Constrained Economic Dispatch algorithm that dispatches the real-time market or via special controls to emulate the performance of a proxy AC line with a lower impedance per mile than physically practical. The merchant HVDC lines may be intra-regional or interregional lines that are proposed, paid for and scheduled by a merchant who obtains interconnection service from all interconnected transmission providers which includes funding of any AC network upgrades required to support the operation of the merchant HVDC line within the operating requirements and restrictions of the interconnection agreement. The following figures provide conceptual representations of the current HVDC configuration, MISO's regionally planned and merchant HVDC configurations, owner-scheduled, intra-regional, and merchant interregional HVDC configurations.

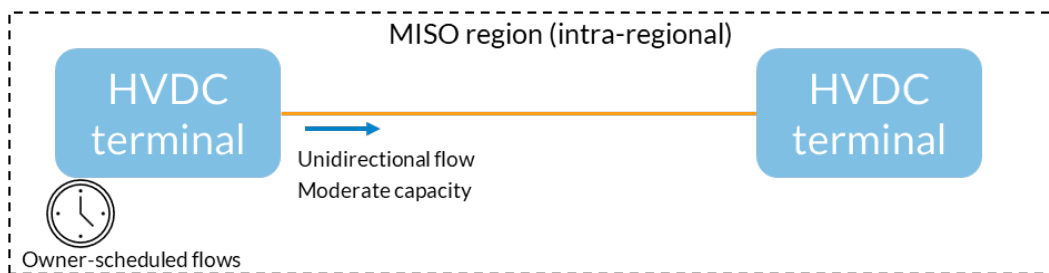

Figure 3: Current HVDC (originally built as generation lead lines)

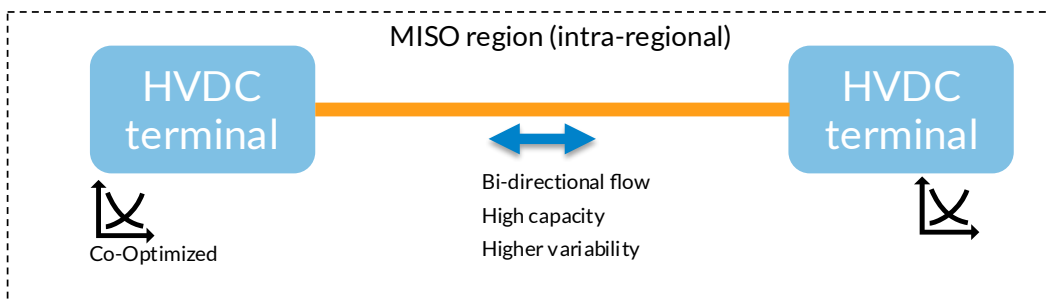

Figure 4: Regional Planning

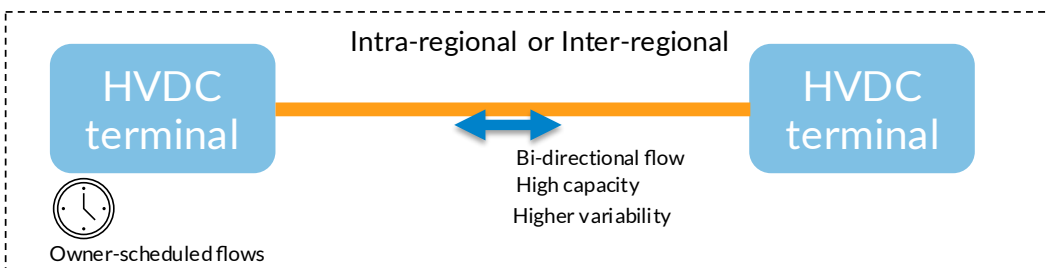

Figure 5: Merchant HVDC



## 2 Market Impact Assessment

HVDC technology offers unique controllability and efficiency benefits for both intra-regional transmission within MISO and interregional connections to neighboring systems. While MISO has successfully integrated several HVDC facilities under existing frameworks, the increasing number of proposed projects, particularly merchant-led interregional developments, presents new operational and market design challenges.

### Key Insights

- **Current HVDC models are fragmented and case-specific**, limiting MISO's ability to support scalable, dispatchable HVDC integration across both intra- and inter-regional contexts.
- **Intra-regional HVDC facilities are not fully co-optimized with generation and load**, which can exacerbate AC congestion and reduce market efficiency. Enhanced SCED integration and loss modeling are needed to unlock their full value.
- **Existing interregional coordination mechanisms (M2M, CTS) were designed for AC systems** and do not leverage HVDC's controllability. New coordination levels and participation models are needed to support dynamic interchange and congestion relief.

### Recommendations

- **Interchange and congestion management:** As penetration of HVDC increases, MISO should evaluate approaches to integrate HVDC into interchange and market-to-market congestion management processes and discuss these approaches with our neighbors.
- **Intra-regional HVDC:** As HVDC penetration increases, MISO should evaluate potential approaches from other RTOs to partially integrate intra-regional HVDC into market and operations practices. Additionally, MISO could continue to research open questions related to full integration.
- **HVDC and congestion hedging processes:** MISO could assess the risk of FTR underfunding and possibility of missed hedging opportunities and evaluate potential process enhancements to better align FTR auctions with evolving operational practice.

### CURRENT STATE OF MISO MARKET OPERATIONS

MISO currently supports three HVDC participation models, each developed for specific operational needs and commercial contexts (see Figures 3, 4, and 5 in the Background section for HVDC configuration types). These models reflect not only physical topology but also how HVDC-enabled flows interact with MISO's market systems such as dispatchability, Balancing Authority (BA) relationships, and congestion management. This section summarizes their key characteristics and limitations to assess their suitability for emerging HVDC use cases. While effective within their original scope, these models were developed case-by-case with opportunities remaining to further optimize HVDC, and they do not form a unified framework capable of supporting the diversity of HVDC projects now emerging.



## **GENERATION LEAD LINE MODEL**

This model applies to HVDC lines that are dedicated to delivering energy from a specific generation facility to the MISO grid. These lines are typically intra-regional, operate entirely within MISO's Balancing Authority Area (BAA) and are not used for regional congestion management or broader market transactions. To simplify integration and reflect their dedicated purpose, MISO models HVDC generation lead lines as part of the generator rather than as standalone transmission assets. The HVDC interface is represented using fictitious units: one at the source side, where the generator injects power into the HVDC line, and one at the sink side, where power is delivered to the AC grid. These two units are not electrically connected in the network model. This representation avoids unnecessary AC network complexity and allows the generator to manage HVDC flows directly. It also decouples pricing between terminals, reflecting the fact that the HVDC line bypasses the AC network and does not contribute to congestion between those points.

Because the sink-side unit is where power enters AC grid, it is the point that is visible to MISO's market systems. Ancillary Services such as regulation and contingency reserves are typically offered at the sink-side node. Energy offers may be submitted at both terminals, depending on the modeling configuration. Because the fictitious units are not electrically connected, the HVDC line itself is not directly optimized in SCED. Instead, the generator is responsible for adjusting HVDC flows to match cleared output. Current implementations (e.g., Coal Creek to Dickinson and Square Butte to Arrowhead<sup>4</sup>) operate entirely within the MISO BAA.

## **RELIABILITY ASSET (FIXED/MANUAL SCHEDULE)**

This model applies to intra-regional HVDC lines operated manually under fixed or pre-arranged schedules, without real-time market optimization. The Mackinac HVDC facility illustrates this approach: it is modeled using two fictitious units, one at the source and one at the sink, that are not electrically connected in the network model. HVDC losses are excluded from Locational Marginal Prices (LMPs) and handled outside the dispatch engine. While energy and ancillary service offers may be submitted at both terminals, they do not influence HVDC dispatch, which remains manual. These offers may clear independently based on local conditions but are not co-optimized with HVDC transfers.

## **DYNAMIC TRANSFER (EXTERNAL ASYNCHRONOUS RESOURCE)**

This model enables participation of external resources that are not synchronously connected to MISO's grid. These resources are integrated into MISO's Day-Ahead and Real-Time markets through dynamic scheduling and proxy modeling. Manitoba Hydro is the primary example: its generation fleet is in northern Manitoba and electrically decoupled from the Eastern Interconnection via an internal HVDC system.

MISO models Manitoba as an External Asynchronous Resource (EAR), allowing it to submit market offers that are co-optimized through SCED every five minutes. Once cleared, EARs receive dispatch targets like internal resources. They are modeled at proxy points on the AC side of the HVDC interface, as they are not physically located within MISO's balancing area, and their output is reflected in market settlements. To facilitate interchange, EARs must submit a Fixed Dynamic Interchange Schedule via a dynamic e-Tag.

---

<sup>4</sup> Square Butte was originally modeled as a unidirectional generation lead line but now supports both injections and withdrawals.



This tag includes a pre-approved hourly schedule and a dynamic energy profile that reflects expected 5-minute dispatch levels. While the e-Tag itself is not updated sub-hourly, the physical interchange is expected to follow the SCED-cleared dispatch. Deviations are monitored, and the dynamic profile is used to align physical flows with market instructions without requiring continuous tag updates.

This structure supports both import and export transactions, allowing EARs to offer energy (positive or negative) and ancillary services such as Regulation and Contingency Reserves. Importantly, MISO does not calculate sensitivities directly across the HVDC line. Instead, congestion management is handled at the AC-side proxy nodes where the EAR is modeled. This approach is effective because EAR dispatch is not expected to cause congestion on Manitoba's AC system, allowing MISO to manage impacts without modeling the external network in detail.

## **SUMMARY OF CURRENT STATE**

MISO's current HVDC facility models were developed to serve specific operational and commercial needs. As HVDC proposals diversify in design and purpose, participation models will need to accommodate configurations ranging from short back-to-back links to long interregional lines. While the specific instruments and scheduling mechanisms may vary, MISO's approach to market integration: dispatch, loss modeling, and controllability should all align within a consistent optimization framework. To inform potential enhancements to MISO's HVDC integration framework, it is useful to examine how other grid operators around the world have approached HVDC market participation, optimization, and coordination.

## **BEST PRACTICES FROM OTHER MARKETS**

The way HVDC facilities are integrated into markets depends less on their physical configuration and more on how they are embedded within operational and institutional frameworks. North American examples provide the most directly applicable insights for MISO, as these markets share similar nodal pricing structures, real-time dispatch mechanisms, seams coordination challenges and common regulatory framework. In contrast, international examples reflect different operational and market structures, offering alternative approaches worth considering.

## **NORTH AMERICAN RTO MARKETS**

North American RTOs have adopted varied approaches to HVDC integration, largely shaped by balancing area needs and market design. Intra-BA facilities like CAISO's Trans Bay Cable are integrated into 5-minute SCED but it does not participate directly in Ancillary Services market. In contrast, inter-BA HVDC facilities especially those connecting synchronized systems like PJM and NYISO typically operate under fixed or hourly schedules with limited market optimization. These merchant lines (e.g., Neptune, Cross Sound Cable) generally serve load pockets and are excluded from real-time congestion management because their flows are not co-optimized through joint dispatch.

Asynchronous interties offer greater flexibility. Because asynchronous HVDC decouples system frequency, one RTO can dispatch the resource independently. For example, MISO's integration of Manitoba Hydro via the EAR model allows independent dispatch across BA boundaries enabling participation in 5-minute SCED and ancillary services. However, broader integration challenges persist.



No U.S. RTO currently models HVDC losses in real-time LMPs, and proposed congestion hedging products remain limited to intra-RTO footprints. While some RTOs (e.g., SPP) are exploring option-based Transmission Congestion Rights (TCRs) for controllable transmission, cross-market hedging remains unsupported due to incompatible settlement systems.

## **GLOBAL HVDC MARKET INTEGRATION**

HVDC infrastructure is widespread globally, with significant deployments in Asia, South America, and other regions. However, most of these systems operate under centralized planning models or utility-controlled dispatch that offer limited insights for market-based RTO environments. Two market-based systems, Australia's National Electricity Market (AEMO) and Europe's coordinated market coupling framework, provide useful comparisons. Both demonstrate more advanced sub-hourly optimization approaches than most North American inter-BA implementations, though under fundamentally different institutional and market structures than US nodal markets.

More details about the North American RTO HVDC market integration and global HVDC integration are included in the Appendix, section on “Comparative Analysis of HVDC Market Integration.”

## **IMPLICATIONS FOR MISO**

For MISO, the examples above highlight a range of design choices and modeling practices that can inform how intra-regional HVDC might be integrated into MISO's market systems. North American cases reveal persistent barriers to synchronized inter-BA HVDC dispatch such as differences in market rules, settlement systems, and operational coordination. A unified optimization framework for HVDC in MISO will require not only improved modeling but also scalable coordination mechanisms that reflect the diversity of project types and dispatch authorities. These insights point to the need for solutions that align with MISO's specific operational context.

## **INTRA-REGIONAL HVDC OPTIMIZATION**

Intra-regional HVDC facilities within MISO's footprint present different market integration considerations than interregional facilities that span RTO boundaries. While interregional coordination must address seams issues and multi-party settlement, intra-regional HVDC can potentially leverage MISO's existing dispatch framework for economic optimization. This section outlines the technical considerations and modeling refinements that would be required to support such integration within MISO's economic dispatch process.

## **DISPATCH INTEGRATION IN SCED**

Integrating HVDC into MISO's SCED framework would allow controllable HVDC flows to be co-optimized with generation and load, enabling the system to dynamically respond to congestion, price signals, and system conditions. In this model, HVDC line flows become dispatch variables, with offers and bids submitted at both terminals. This allows the HVDC line dispatch to relieve AC line transmission constraints, support economic transfers, and enhance system flexibility. However, modeling HVDC as a controllable transmission element introduces complexity, as it affects power balance at both terminals and interacts with AC constraints.



MISO's preliminary SCED formulations have shown promise under positive pricing but revealed challenges under negative prices, including circular flows and loss-maximizing dispatch. These issues stem from simplified, linear loss approximations which do not accurately reflect the relationship between losses and flow magnitude or direction. Additional challenges include oscillatory dispatch behavior, inaccurate loss modeling for large HVDC transfers, and potential stability concerns in weak AC areas. Addressing these issues requires enhancements such as piecewise or hybrid loss models, integer variables for flow direction, and angle difference constraints to prevent circular flows.

Other RTOs have implemented practical solutions that offer near-term guidance. As a transmission asset under CAISO operational control, the Trans Bay Cable is integrated into the five-minute dispatch to manage congestion. It does not actively bid into ancillary service markets. HVDC losses are not modeled explicitly within the market optimization. NYISO, meanwhile, uses a proxy bus model and a two-part settlement structure that reflects both day-ahead schedules and real-time deviations. This approach enables economic optimization of HVDC flows while maintaining operational control and ensuring losses are reflected in pricing and settlement. These examples demonstrate that partial integration is feasible and can inform MISO's path forward.

### **ANCILLARY SERVICE PARTICIPATION**

Dispatchable HVDC facilities could provide ancillary services to support grid reliability and operational flexibility. Generation resources at the sending terminal could offer regulation and operating reserves, while load resources at the receiving terminal could participate in demand response programs. The controllability of HVDC enables ancillary service delivery across internal transmission constraints that might otherwise limit resource participation.

### **CONGESTION HEDGING FOR INTRA-REGIONAL HVDC**

As dispatchable HVDC becomes integrated into SCED, MISO will need to evaluate how congestion revenues are allocated and whether existing Financial Transmission Rights (FTRs) provide adequate hedging coverage. Current FTR frameworks were designed for AC transmission and do not account for the directional and controllable nature of HVDC. Other RTOs offer contrasting models: NYISO and CAISO generally exclude HVDC from their congestion rights markets to preserve dispatch flexibility. SPP has developed an 'option-style' settlement proposal for DC ties connecting the Eastern and Western interconnections. Under this framework, congestion rights across the back-to-back facilities would function as options rather than obligations, protecting holders from counter-flow payments. These examples highlight that the appropriate hedging structure depends on multiple factors including the facility's dispatchability, market integration, and role in congestion management. MISO may need to evaluate flexible approaches such as segmented settlement or optionality-based rights to determine whether they align with its operational and market framework.

### **TECHNICAL CHALLENGES**

Dispatchable HVDC integration into SCED presents several technical challenges that require careful modeling. These include circular flow behavior, loss modeling inaccuracies, and interactions with AC system constraints.



**Circular flows** can arise when HVDC interacts with AC congestion or negative pricing in ways that create looped transfers. These flows may appear economically rational in the optimization but are physically inefficient or infeasible. They can occur under both fixed and dispatchable HVDC schedules and are exacerbated when the optimization inadvertently maximizes losses under negative LMPs. Even under positive prices, circular flows may emerge when HVDC is used to relieve AC congestion, especially in systems with strong parallel AC paths.

**Loss modeling** is another important consideration. MISO's current SCED uses linear loss sensitivity factors, which are generally sufficient for small AC redispatch but become inaccurate with large HVDC transfers. Piecewise linear (PWL) or hybrid loss models offer better accuracy but introduce complexity, especially under negative prices, where the optimization may favor high-loss segments unless constrained. Without proper modeling, dispatch outcomes may become oscillatory or non-physical.

**System stability** issues may also arise. HVDC facilities, especially based on voltage source converter technology, have the technical capability to support voltage and frequency stability. However, HVDC dispatch can interact with AC system in ways that might increase overall system stress and create stability issues. The HVDC converter interactions are even more prominent in weak AC areas, requiring further evaluation outside the SCED framework.

MISO, in collaboration with NLR, is actively researching modeling enhancements to support dispatchable HVDC, including improved loss modeling, circular flow mitigation, and flow direction optimization. While these challenges are real, other RTOs have already implemented practical solutions that offer near-term guidance. As discussed earlier, CAISO and NYISO provide contrasting but instructive models for integrating HVDC into real-time dispatch and settlement. These examples show that partial integration is both feasible and effective. MISO may evaluate these potential approaches to partially integrate intra-regional HVDC into market and operational practices. In parallel, ongoing research could address open questions related to full integration. For additional modeling details and mathematical formulations related to intra-regional HVDC integration, see the Appendix section titled "Technical Formulations for Intra-Regional HVDC."

## INTERREGIONAL HVDC COORDINATION AND MARKET PARTICIPATION

Existing interregional coordination mechanisms were designed for AC systems, where flows follow physical laws and cannot be directly controlled. HVDC, by contrast, offers controllability that introduces new flexibility for both scheduling and congestion management. This contrast highlights the need to reassess current frameworks and identify enhancements to better align with HVDC capabilities.

### EXISTING INTERREGIONAL COORDINATION PROCESSES

MISO coordinates interregional flows using four legacy mechanisms: Market-to-Market (M2M), Coordinated Transaction Scheduling (CTS), Transmission Loading Relief (TLR), and Phase Angle Regulators (PARs). These were designed for conventional AC systems with fixed, scheduled flows. While these mechanisms govern how flows are economically or operationally coordinated between RTOs, all resulting interchange - whether from CTS, bilateral agreements, or other sources - must be submitted through the NERC-administered e-Tag system. Coordination practices vary by neighbor: MISO uses market-based coordination with PJM and SPP; bilateral scheduling with TVA and AECI; and asynchronous



coordination with Manitoba Hydro through the EAR model. Each mechanism reflects the operational and market arrangements in place with the respective entity.

### ***NERC-ADMINISTERED E-TAG SYSTEM***

Although not a coordination mechanism itself, the e-Tag system is a primary compliance tool that documents and implements scheduled transactions across balancing areas. Regardless of how interchange is determined such transactions must be submitted and approved via e-Tags. While essential for reliability and compliance, e-Tags are not updated in real time and do not support sub-hourly adjustments, limiting their ability to reflect HVDC's fast controllability.

### ***TRANSMISSION LOADING RELIEF (TLR)***

TLR is a reliability-based curtailment procedure used when transmission constraints threaten to exceed system limits. Administered under NERC standards, TLR identifies and curtails scheduled transactions that contribute to constrained flowgates based on their calculated impact and firmness. It is a reactive tool, invoked when other coordination mechanisms are unavailable or insufficient. TLR does not consider economic efficiency, lacks financial settlement, and operates independently of market dispatch. HVDC schedules submitted via e-Tags may be curtailed under TLR, but the process does not leverage HVDC's controllability to manage congestion proactively.

### ***PHASE ANGLE REGULATOR (PAR) COORDINATION***

PARs are AC flow control devices used to manage loop flows across seams, such as those between MISO and Ontario's Independent Electricity System Operator (IESO). They adjust the phase angle of voltage to steer power flows across parallel AC paths. PAR coordination is governed by bilateral protocols and focuses on meeting agreed flow targets through tap adjustments. While PARs offer controllability, they operate within a reliability framework and are not integrated into market-based redispatch or interchange optimization. HVDC, by contrast, provides direct point-to-point control and could complement PARs if coordinated effectively. However, current frameworks do not account for interactions between HVDC injections and AC flow control devices like PARs.

### ***COORDINATED TRANSACTION SCHEDULING (CTS)***

CTS is a forward-looking interchange scheduling mechanism jointly implemented by MISO and PJM. It allows market participants to submit interface bids based on forecasted price difference between proxy buses in each RTO. These bids are evaluated and cleared every 15 minutes, resulting in scheduled interchange that reflects expected economic arbitrage opportunities. CTS was designed to improve the efficiency of scheduled interchange by aligning it more closely with real-time price signals, while preserving the independence of each RTO's dispatch.

Despite its market-based design, CTS is limited in its responsiveness and scope. Bids must be submitted at least 75 minutes in advance, and once cleared, the resulting schedules are fixed for the delivery interval. This lag between bid submission and flow execution reduces the ability to respond to real-time system conditions, especially under volatile or uncertain conditions. Moreover, CTS does not coordinate with M2M redispatch. If CTS-induced flows contribute to congestion, the resulting impacts are managed reactively through M2M, not through adjustment of CTS schedules. HVDC facilities, which can adjust



flows dynamically, are not integrated into the CTS framework and do not participate in the bid-clearing process. While HVDC injections may influence LMPs at proxy buses, CTS does not explicitly model or leverage HVDC controllability.

### **MARKET-TO-MARKET (M2M) FLOWGATE COORDINATION**

M2M coordination is the primary mechanism for managing real-time congestion across market-based seams, such as those between MISO and PJM or SPP. It was designed to replace reliability-based curtailment with economic redispatch, allowing each RTO to relieve congestion on jointly monitored flowgates using its own internal generation. When a flowgate becomes constrained, the monitoring RTO sends its shadow price to the non-monitoring RTO. If the non-monitoring RTO can provide relief more economically, it redispatches generation to reduce its contribution to the constraint. This process runs every five minutes and is aligned with each RTO's SCED cycle. A summary table of coordination mechanisms with neighboring entities is provided in the Appendix under "Coordination Mechanisms by Neighboring Entities".

However, M2M was built around the assumption of fixed net interchange and does not include mechanisms to coordinate controllable transmission assets like HVDC. HVDC flows are treated as part of the fixed interchange baseline and are not redispatched through the M2M process. While HVDC can materially affect flowgate congestion, the current framework lacks the ability to request or respond to HVDC adjustments. Shadow price exchange provides a signal of congestion cost but does not convey HVDC availability, ramp capability, or economic value. As a result, HVDC flexibility remains untapped in M2M coordination, limiting its potential to support congestion relief across seams.

### **LIMITATIONS OF CURRENT COORDINATION MECHANISMS FOR HVDC**

Despite the range of mechanisms available for interregional coordination several structural and operational gaps remain. These gaps are not specific to HVDC but reflect broader limitations in how congestion and interchange are managed across seams.

**Timing misalignment:** MISO's coordination tools operate on different timescales. M2M runs every 5 minutes in sync with SCED, while CTS clears every 15 minutes but requires bids 75 minutes ahead. TLR is purely reactive, triggered only when constraints bind. These mismatched timelines can lead to inefficient flows, especially when forecasts diverge from real-time conditions. HVDC's fast controllability could improve outcomes but leveraging it requires more frequent or forward-looking coordination balanced against added data and computational demands.

**Reactive and delayed congestion management:** Most existing tools are inherently reactive. TLR is triggered by reliability violations, and M2M redispatch begins only after a constraint is binding and coordination thresholds are met. Even then, the Independent Market Monitor has noted that administrative delays in M2M activation can reduce the timeliness and effectiveness of relief<sup>5</sup>. These lags can result in higher congestion costs and missed opportunities for early intervention, especially problematic when HVDC could have provided fast, targeted relief had it been integrated into the process.

---

<sup>5</sup> [2023 State Of The Market Report \(https://www.potomaceconomics.com/wp-content/uploads/2024/08/2023-MISO-SOM\\_Appendix\\_Final.pdf\)](https://www.potomaceconomics.com/wp-content/uploads/2024/08/2023-MISO-SOM_Appendix_Final.pdf)



**Incomplete information exchange** Coordination frameworks must balance HVDC dispatch flexibility with the need to manage its impact on AC network constraints in both systems. The right approach depends on the HVDC project's purpose, the institutional relationship between RTOs, available infrastructure, and stakeholder preferences. Effective coordination requires richer information exchange, such as shadow prices, LMPs at both terminals, ATC, ramp rates, and real-time relief potential. The level of detail needed varies by model: unilateral dispatch may need less, while bilateral optimization requires more. Tailoring information exchange to the coordination model is crucial to leveraging HVDC controllability.

**Structural misalignment with HVDC capabilities:** Current mechanisms assume that transmission is either passive (AC) or scheduled in advance (interchange). Neither M2M nor CTS is designed to coordinate dynamically dispatchable transmission assets. For example, M2M treats HVDC flows as fixed contributions to market flows, excluding them from redispatch logic. CTS assumes participant-driven scheduling, not operator-controlled dispatch. TLR and PAR coordination are reliability tools with no economic optimization. These limitations become increasingly problematic as neighboring systems integrate higher levels of renewable generation, creating more volatile dispatch patterns and rapid changes in interchange needs that current coordination frameworks cannot efficiently manage.

## INTERREGIONAL COORDINATION RESEARCH WITH NLR

Recent research by NLR, academic institutions, and industry collaborations has explored ways to improve interregional coordination in systems with diverse resources and controllable transmission. These efforts offer conceptual frameworks and practical tools for evaluating coordination alternatives that align with evolving system needs, particularly in the context of HVDC.

### OPERATIONAL MECHANISM: REAL-TIME AND FORWARD PROCESS INTEGRATION

A key focus of this work is enhancing coordination between RTOs where controllable transmission, such as HVDC, is involved. While nodal markets have advanced internal optimization through tools like Security Constrained Unit Commitment (SCUC) and SCED, coordination across seams remains fragmented. Responsibilities for power balance, reserves, and congestion management are distributed across entities, which can limit overall system efficiency. MISO is continuing its collaboration with NLR to identify scalable strategies for HVDC coordination that reflect these operational realities.

NLR's research categorizes real-time coordination methods into several tiers of complexity and responsiveness. These include basic shadow price exchange (RT1), price curve sharing (RT2), marginal resource representations (RT3), and relief cost curve exchange (RT4). Each approach offers trade-offs in terms of communication overhead, responsiveness, and implementation complexity. HVDC adds further flexibility but also requires mechanisms to determine flow direction, ramping, and congestion impacts in near real-time. Coordination models must account for these dynamics without introducing instability or excessive operational burden.

### MULTI-ENTITY COORDINATION FRAMEWORKS

To support this, NLR has developed a framework to assess how RTOs manage four key constraints:



*Power Balance:* Each RTO ensures that generation matches load plus losses and interchange. Coordination at this level involves aligning net interchange schedules or enabling dynamic adjustments through mechanisms like HVDC dispatch.

*Transmission Constraints (Energy Flow)* RTOs manage congestion on internal flowgates using SCED. Coordination here involves sharing shadow prices or redispatch responsibilities for jointly monitored flowgates, as in M2M processes.

*Reserve Requirements:* RTOs procure and deploy reserves to meet reliability standards. Coordinating reserve procurement or sharing reserve capacity across seams is rare but could improve system flexibility.

*Transmission Constraints (Energy + Reserve Flow):* These constraints ensure that the system can deliver reserves under post-contingency conditions. Coordination at this level is complex and typically not implemented across RTOs today.

Depending on their operational goals, RTOs can coordinate on any combination of system constraints. While full coordination across all four categories may be impractical, targeted enhancements like incorporating HVDC into real-time congestion management or enabling forward interchange coordination can deliver meaningful benefits. MISO will continue working with NLR to evaluate scalable coordination methods that better leverage HVDC controllability without requiring full integration.

## **IMPLICATIONS FOR INTERREGIONAL HVDC OPTIMIZATION**

Interregional HVDC can both relieve AC congestion and dynamically optimize net interchange between RTOs, but current coordination frameworks, designed for fixed interchange and generation redispatch limit its potential. Real-time HVDC dispatch remains constrained by institutional boundaries, incomplete data exchange, and lack of protocols for dynamic control. Forward coordination could improve efficiency, especially under high renewable conditions, while real-time integration into SCED could enable one RTO to dispatch HVDC for both internal and interregional relief. However, this raises questions around dispatch authority, settlements, and system impacts. Flexible, scalable coordination models could deliver significant benefits without requiring full joint optimization.

## **POTENTIAL MISO ENHANCEMENTS FOR INTERREGIONAL HVDC COORDINATION**

Merchant HVDC developers are proposing interregional transmission facilities that recover costs through capacity sales rather than regulated rates. Unlike utility-owned transmission integrated into the RTO tariff, merchant HVDC operators retain commercial control over their facilities while selling transmission capacity to multiple independent participants. This structure requires MISO to coordinate with the HVDC operator on physical dispatch while also managing energy transactions from multiple resources using the line's capacity. The HVDC line's capabilities can only be fully utilized if the external resources enabled by it are able to participate in a manner that supports MISO's market efficiency and grid reliability. This type of dual coordination is not supported by existing frameworks.

## **CANDIDATE COORDINATION APPROACHES FOR MERCHANT HVDC**

While earlier sections have outlined the limitations of existing coordination mechanisms, merchant HVDC projects introduce additional complexity that may require new or enhanced approaches. Table 1



compares three candidate coordination models, illustrating how each differs in terms of dispatch authority, interchange optimization, congestion management, and information exchange. This comparison helps clarify the trade-offs between implementation complexity and operational flexibility.

Coordination Approach	HVDC Role	Interchange Optimization	Congestion Management	Information Exchange
<b>Level 0: Merchant Control</b>	Fixed parameter (merchant sets schedule)	No	Generation redispatch only	Shadow prices + relief requests
<b>Level 1: HVDC for M2M Congestion Relief</b>	Provides M2M relief within fixed interchange	No (fixed net interchange)	HVDC + generation redispatch	Shadow prices + relief requests
<b>Level 2: Interchange Optimization</b>	Economic dispatch + relief capability	Yes (15-min ahead or real-time)	HVDC + generation redispatch	Shadow prices + forecasted or real-time price/quantity coordination

**Table 1 Comparison of Candidate Coordination Approaches for Merchant HVDC**

### **Level 0: Merchant Control (Status quo)**

The HVDC owner independently schedules flows, with no RTO dispatch authority. Flows are treated as fixed interchange, and coordination occurs through existing M2M processes, which do not adjust HVDC flows. When the HVDC flows contribute to flowgate congestion, both RTOs are limited to reliability-based curtailment. This approach is similar to current M2M framework and simple to implement but does not leverage HVDC’s controllability.

### **Level 1: HVDC for M2M Congestion Relief**

One RTO dispatches HVDC to relieve M2M congestion while maintaining fixed net interchange. The neighboring RTO signals congestion via shadow prices but cannot directly request HVDC adjustments. Research by MISO and NLR demonstrates that a single RTO controlling HVDC dispatch can economically provide M2M relief to neighboring RTOs through enhanced information exchange, including HVDC availability and relief capability, but can operate within an enhanced M2M framework.

### **Level 2: Interchange Optimization**

One or both RTOs dynamically dispatch HVDC to optimize interchange and manage congestion. Schedules adjust based on real-time or forecasted prices, affecting power balance and transmission constraints in both systems. This model offers the most flexibility but requires new protocols for bilateral scheduling, real-time coordination, settlements, and M2M impact management.

## **EXTERNAL HVDC-ENABLED RESOURCE PARTICIPATION OPTIONS**

Merchant interregional HVDC creates participation challenges distinct from existing frameworks. When multiple independent resources seek to use capacity owned by a separate transmission provider, questions arise about how resources submit offers, how capacity is allocated, and how schedules are



coordinated across RTO boundaries. Three potential participation approaches could be evaluated, each with different trade-offs:

*EAR Model Extension* would adapt MISO's current single-entity dispatch model to support multiple participants, requiring mechanisms for offer aggregation, flow management, and settlement coordination.

*Pseudo-tie Enhancements* would treat HVDC-enabled resources as internal, but would need to address capacity sharing, M2M impacts, and the distinction between resource and transmission ownership.

*Enhanced Dynamic Transfer* is a conceptual approach that would separate commercial transmission rights from physical operation: the HVDC operator sells capacity to multiple participants who submit offers at an interface node, while retaining operational control. This approach raises design questions around dispatch intervals, data exchange, and settlement structures but offers a scalable path for merchant HVDC integration.

## IMPLEMENTATION CONSIDERATION

The appropriate participation model for merchant HVDC will depend on project-specific factors such as physical configuration, commercial structure, developer preferences, coordination level (e.g., merchant control, M2M relief, or interchange optimization), and agreements with neighboring RTOs. Each model raises design questions around loss allocation, ancillary service coordination, and congestion hedging, requiring collaborative development with stakeholders. While HVDC configurations will vary - from short back-to-back links to long-haul, multi-zone lines - a unified participation model is unlikely. However, consistent treatment in market optimization is achievable through standardized approaches to loss modeling, circular flow mitigation, and financially neutral settlement.

For intra-regional HVDC, enhanced SCED modeling can support economic dispatch; for interregional projects, scalable coordination options can align with different dispatch authorities without requiring full joint optimization. The Enhanced Dynamic Transfer model offers a promising path by separating commercial participation from physical operation. Continued work with NLR, developers, and neighboring RTOs will be essential to refine coordination protocols, ensure transparent loss treatment, and develop hedging mechanisms that reflect HVDC's controllability.



## 3 Reliability Operations Impact Assessment

The reliability impact assessment of HVDC systems is organized into four key areas: i) Stability Impact, ii) Operational Modeling, Monitoring, and Control, iii) Contingency Impact, and iv) Reliability Coordination. The Stability Impact assessment evaluates how HVDC influences rotor angle, voltage, frequency, and converter-driven stability, drawing from extensive literature reviews and Transient Security Assessment Tool (TSAT) simulation results. Operational Modeling, Monitoring, and Control explores how Energy Management System (EMS), Supervisory Control and Data Acquisition (SCADA), and network models can be enhanced to accurately represent HVDC behavior, while also assessing the role of advanced tools such as Phasor Measurement Units (PMUs) and wide-area control systems. The Contingency Impact assessment explains system performance under HVDC outage scenarios. Finally, Reliability Coordination reviews the existing outage coordination framework and potential improvements needed to ensure reliable HVDC integration. Topics related to congestion management and market coordination are covered in the Market Operations section and are referenced here for completeness. While a broader discussion of HVDC technologies is provided in the [Background section of this document](#), this reliability impact assessment focuses primarily on Voltage Source Converter (VSC) systems as most proposed HVDC projects within MISO's footprint utilize VSC-based technology.

### Key Insights

- Due to the large size of some HVDC facilities being considered in the MISO region, the loss of one of these facilities could become the MSSC, thereby increasing contingency reserve requirements and resulting in additional cost impacts.
- HVDC facilities can have impacts on frequency, voltage, and rotor angle stability, and like inverter-based resources, their power electronic controllers may contribute to oscillations.
- HVDC facilities currently operating in MISO participate in both outage coordination and real-time operations processes. However, participation could be enhanced in a variety of ways.

### Recommendations

- **Contingency management procedures for HVDC facilities:** MISO should continue to update the MSSC and contingency reserve requirements as system conditions evolve to ensure reliability. As HVDC penetration increases, MISO should assess the risk of contingency reserve cost increases and evaluate opportunities to mitigate these increases through reserve sharing agreements or alternative cost allocation processes.
- **HVDC impacts on system stability risk:** As penetration of HVDC facilities increases, MISO should conduct, or coordinate with other entities to conduct frequency, voltage, and rotor angle stability risk assessments related to the loss of the HVDC facility as well as assess converter-driven stability risks.
- **Outage coordination and operator visibility for HVDC facilities:** As penetration of HVDC facilities increases, MISO should evaluate more granular representation of de-rates during outage coordination processes, enhanced representation of HVDC facilities in the energy management system and consider other enhancements to improve operator visibility.



## HVDC STABILITY IMPACT ASSESSMENT

HVDC systems, particularly those based on VSC technology, have implications across most categories of the IEEE stability taxonomy.<sup>6</sup> A qualitative review conducted by dynamics studies subject matter experts, supported by prior MISO work and findings from other ISOs/RTOs, identified both potential benefits and risks.

The MISO Renewable Integration Impact Assessment (RIIA) noted that VSC-HVDC lines enhance capabilities for power flow control, reactive power and voltage support, dynamic stability, and synthetic inertia.<sup>7</sup> The RIIA study introduces HVDC as a dynamic stability solution starting at the 30% renewable energy milestone, with significant HVDC stability solutions introduced at the 40% milestone. Figure 6 shows the level of HVDC solutions, relative to other solutions, deployed in the RIIA study to resolve stability constraints introduced by increasing levels of renewable energy.

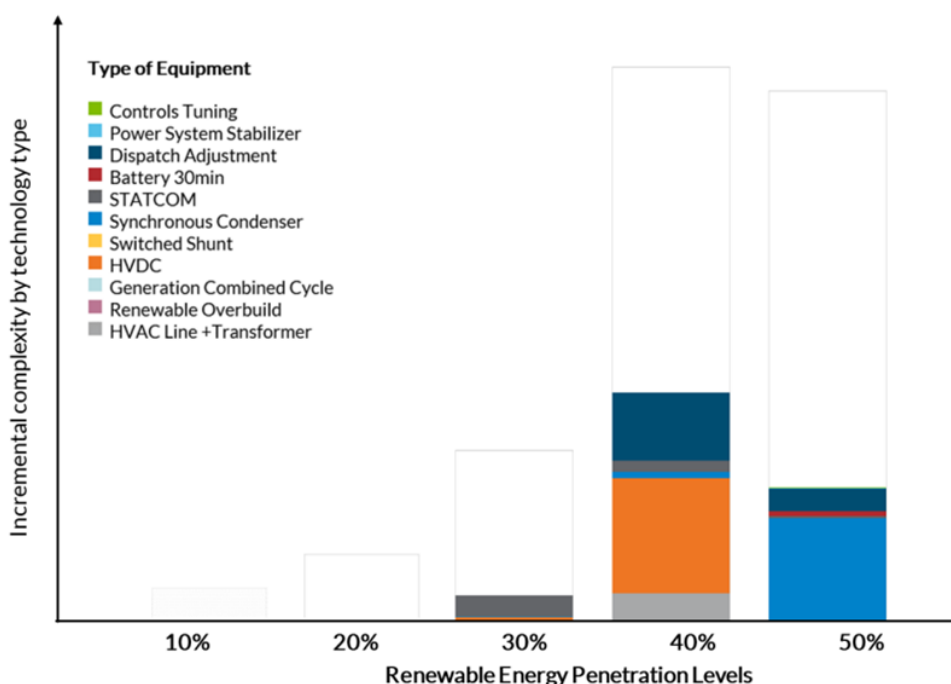

Figure. 6: Dynamic stability solutions -incremental complexity by technology for each renewable penetration milestone (reproduction of RIIA Figure UC-12)

The RIIA study deployed VSC-HVDC as a solution based on recognized stability benefits that include

- **Fast dynamic response:** Independent control of active and reactive power enables P-Q modulation within 10–50 milliseconds for voltage and frequency support
- **Four-quadrant operation:** Bidirectional transfer of real and reactive power
- **STATCOM functionality:** Reactive power support without active power transfer

<sup>6</sup> N. Hatziargyriou *et al.*, "Definition and Classification of Power System Stability – Revisited & Extended," in *IEEE [Institute of Electrical and Electronics Engineers, Inc.] Transactions on Power Systems*, vol. 36, no. 4, pp. 3271-3281, July 2021

<sup>7</sup> MISO, Renewable Integration Impact Assessment. <https://cdn.misoenergy.org/RIIA%20Summary%20Report520051.pdf>



- **Operation in weak systems:** Suitable for operation in grids with low Short Circuit Ratio (SCR)
- **Fault ride-through:** Maintains oscillation damping during grid disturbances
- **Grid-forming capability:** Functions as a voltage source, enabling system restoration and support
- **Grid strengthening:** Increases effective SCR at the point of interconnection, similar to grid-forming inverters
- **Active oscillation damping:** Supports system stability through controller-based damping

However, these benefits are highly dependent on control system design, grid strength, and technology. Poorly tuned or uncoordinated HVDC systems may introduce adverse control interactions and degrade overall system stability. Converter driven stability, or the potential for HVDC to interact with other inverter-based resources, is potentially the greatest current risk of HVDC. Certain types of resonant stability such as sub-synchronous control torsional interactions (SSCTI) were observed in early HVDC installations, posing reliability challenges. The following subsections detail the potential positive and negative operational reliability impacts of HVDC across these categories. Figure 7 provides a more nuanced view of the benefits and risks associated with HVDC.

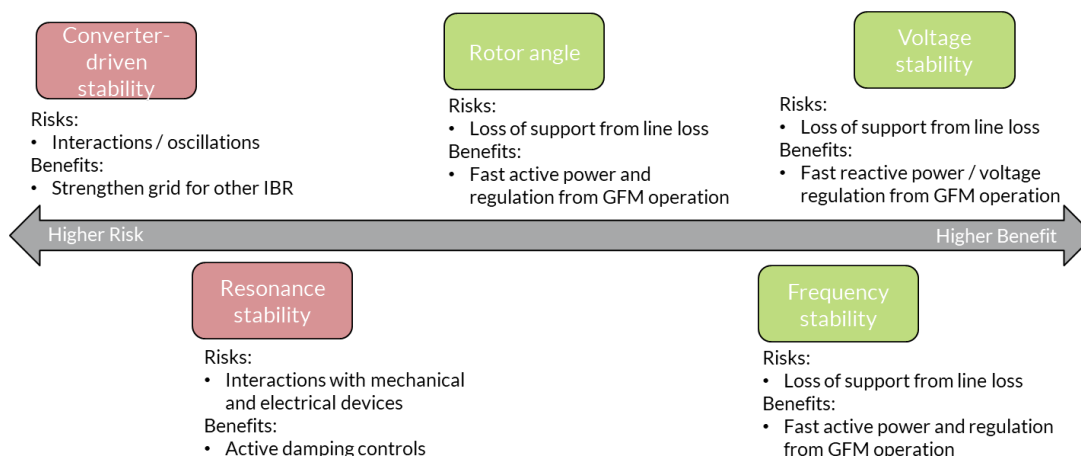

Figure 7: Conceptual risks and benefits of VSC-HVDC lines and stability

## ANGULAR STABILITY SUPPORT

HVDC systems enhance angular stability by decoupling interconnected AC areas, allowing power transfer to remain stable even during large post-fault swings that could destabilize an AC inertia. This electrical separation prevents disturbances in one region from driving oscillations in another. Additionally, HVDC controls can rapidly modulate real power during and after faults, limiting rotor-angle excursions and improving the overall post-fault network stress. The [technical appendix](#) illustrates, using a simplified 176-bus model of Western Electricity Coordinating Council (WECC), how a fast HVDC power transfer can reduce the relative phase-angle differences and lower overall network stress.<sup>8</sup>

<sup>8</sup> S. M. Rovnyak, D. W. Longbottom, D. C. Vasquez, and M. N. Nilchi, "Response-based event detection for one-shot wide-area stability controls," in *Monitoring and Control using Synchrophasors in Power Systems with Renewables*, ser. Books, pp. 177–200, June 29, 2020, [https://doi.org/10.1049/pbpo121e\\_ch8](https://doi.org/10.1049/pbpo121e_ch8)



## VOLTAGE STABILITY SUPPORT

For voltage stability benefits, VSC-based HVDC can almost instantaneously inject or absorb reactive power independent of active power, allowing STATCOM operation. VSC terminals can be designed with full reactive power capabilities. As highlighted in the [technical appendix](#), these benefits have been demonstrated in international grids over the past decade.

The instantaneous reactive power response can be illustrated in a simple test system, such as one described by Figure 8 with a 400 MW VSC-based HVDC link. A representative simulation involves playing back lower voltage steps at the inverter-side Point of Interconnection (POI) bus i.e., bus 4.

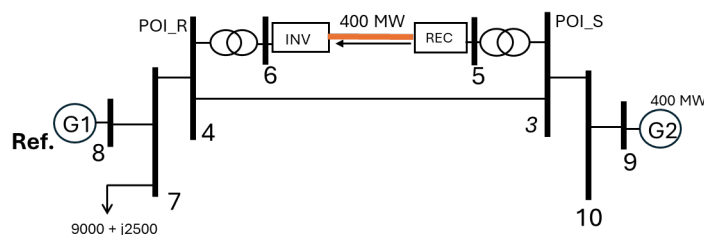

Figure 8: HVDC test system

Two step-reductions in the POI bus voltage are introduced – the first at 2 seconds, and the second at 6 seconds as shown in Figure 9. The V-Q dynamics demonstrate that the inverter’s reactive power shifts from an initial state of absorption (negative Vars) to injection (positive Vars). At 2 seconds, the reactive power injection is increased by 109% relative to its pre-disturbance value.

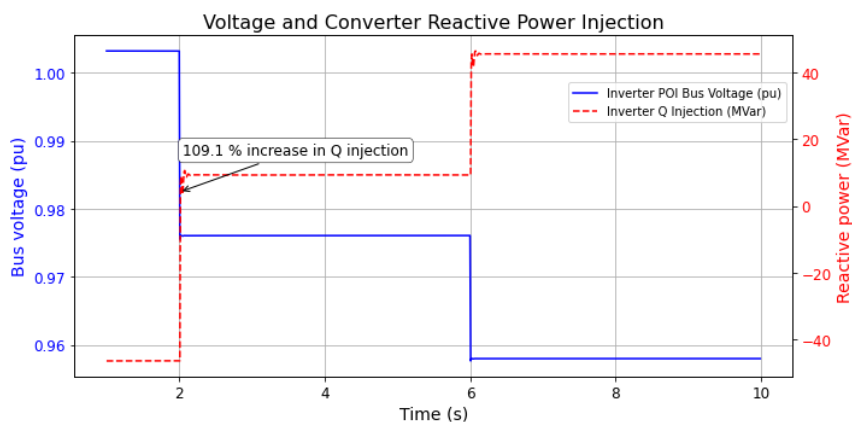

Figure 9: Low voltage test for VSC converter

Similarly, VSC-based HVDC systems can operate reliably under weak grid conditions. A weak grid can be emulated by increasing the impedance between the converter’s POI and the surrounding AC network, thereby reducing the Short-Circuit Ratio (SCR) seen by the converter. The SCR test has been explained in the [technical appendix](#).



These tests serve as proxies for validating the inherent behavior of HVDC dynamic models. In practice, system operators and planning engineers may require more extensive model validation to maintain planning accuracy and reliability. As discussed in the [Transmission Planning](#) section later in this paper, evaluating such dynamic reactive power benefits from HVDC also requires understanding what alternative sources of dynamic reactive support already exist and whether those sources would remain available independently of the HVDC line.

## FREQUENCY STABILITY SUPPORT

VSC-HVDC also supports frequency stability across all relevant timescales for frequency recovery through droop-based control and synthetic inertia. Inertia control makes the VSC converter respond to the rate of change of frequency (ROCOF) and can be emulated by using grid-forming control strategies that utilize the energy stored in the DC-link capacitors. These systems enable fast frequency responses, with active power modulation achievable within 10 to 50 milliseconds.<sup>9</sup> Primary frequency control is implemented through droop control mechanisms, analogous to those used in synchronous machines. Standardization around frequency response is found in ENTOS-e's HVDC Grid code.<sup>10</sup>

## CONVERTER-DRIVEN STABILITY RISKS

Despite all the stability benefits of HVDC, converter-driven stability issues may arise from dynamic interactions between HVDC converters and other power electronic devices, such as inverter-based resources (IBRs) or large converter-fed loads. While VSC-HVDC systems can improve local system strength, particularly in weak grid areas, they can also introduce or amplify control-based instabilities under certain conditions. Findings from the MISO RIIA indicate potential converter-driven stability concerns beginning at the 30% renewable penetration milestone. These concerns align with projections from the Regional Resource Assessment (RRA), which anticipates localized weak-grid conditions as renewable integration increases. Even the HVDC stability benefits are highly dependent on control system design, grid strength, and technology. Poorly tuned or uncoordinated HVDC systems may introduce adverse control interactions and degrade overall system stability.

As an example, converter interaction is found in the Dutch transmission system, where grid operator TenneT has reported persistent sub-synchronous oscillations beginning in 2024.<sup>11</sup> These oscillations typically occur in the 3.4 to 3.8 Hz range, with active power fluctuations around 30 MW and associated voltage variations of approximately 1% of nominal voltage. The events are most frequently observed during summer, particularly at mid-day, and are concentrated near HVDC terminals connecting lines to Denmark and Norway. These areas also host a high density of solar PV generation near the HVDC

---

<sup>9</sup> Stojković, J., Lekić, A., & Stefanov, P. (2020). Adaptive Control of HVDC Links for Frequency Stability Enhancement in Low-Inertia Systems. *Energies*, 13(23), 6162. <https://doi.org/10.3390/en13236162>

<sup>10</sup> European Union, Commission Regulation (EU) 2016/1447 of 26 August 2016 establishing a network code on requirements for grid connection of high voltage direct current systems and direct current-connected power park modules, August 26, 2016, <https://eur-lex.europa.eu/legal-content/EN/TXT/?uri=CELEX:32016R1447#d1e211-1-1>

<sup>11</sup> Tennent, Investigation of persistent sub-synchronous oscillations in the Netherlands. March 2025. <https://www.esig.energy/download/session-4a-investigation-of-persistent-sub-synchronous-oscillations-in-the-netherlands-aleksandar-boricic/?wpdmdl=12932&refresh=67e1709f9b7551742827679>



interface. Phasor Measurement Unit (PMU) data has been essential in capturing and analyzing these oscillatory events.

In China's Xiamen HVDC project, oscillations occurred at 23.6 Hz when operating at 100 MW and shifted to 25.2 Hz at 500 MW, demonstrating a power-dependent frequency characteristic.<sup>12</sup>

In July 2015, China's Hami Wind Farm (a massive 3,000 MW installation of Type-4 wind turbines connected through a weak AC network and  $\pm 800$  kV HVDC) triggered sub-synchronous torsional oscillations around 27–33 Hz.<sup>13</sup> These oscillations, arising from interactions between full-converter turbines and the weak grid, propagated over 300 km and excited torsional modes in remote thermal power units. As a result, protection systems tripped multiple generators, causing a 600 MW loss in capacity and reducing HVDC export capability from 4,500 MW to 3,000 MW.

## STABILITY IMPACT RECOMMENDATIONS

As penetration of HVDC facilities increases, MISO should conduct, or coordinate with other entities to conduct frequency, voltage, and rotor angle stability risk assessments related to HVDC facility as well as assess converter-driven stability risks.

## HVDC OPERATIONAL MODELING, MONITORING AND CONTROL

### CURRENT MODELING PRACTICE

The network topology for MISO HVDC lines is currently modeled differently for the following three different scenarios as described in the [Market Impact Assessment](#) section:

1. Generation-lead intra-regional line
2. Bi-directional scheduled intra-regional line
3. Bi-directional scheduled inter-regional line

The network model supports various real-time analysis functions in the Energy Management System (EMS) such as state estimation, voltage stability analysis, contingency analysis, etc. The way an HVDC system is modeled directly affects what data must be delivered via SCADA. Currently, the SCADA model for HVDC systems includes the following:

1. AC Side Breaker Status
2. AC Side Measurements (MVA, MW, MVAR, and voltage values at the AC terminals)
3. DC Side Measurements (MW at both the sending and receiving ends; two readings for bipoles)

AC-side alarming is supported through both flow-based alarm limits and standard thermal alarms (typically three thresholds). No dedicated DC-side alarms are currently implemented in the SCADA system.

---

<sup>12</sup> Yin, C., Xie, X., Xu, S., & Zou, C. (2018). *Review of oscillations in vsc-hvdc systems caused by control interactions*. The Journal of Engineering, 2019(16), 1204-1207. <https://doi.org/10.1049/joe.2018.8634>

<sup>13</sup> Y. Liu et al., "Stability Problems of Wind Power Integration with Weak AC Grids and Their Solutions," Journal of Engineering (IET), 2017. DOI: [10.1049/joe.2017.0612](https://doi.org/10.1049/joe.2017.0612)



The Inter-control Center Communication Protocol (ICCP) model manages the communication infrastructure that supports SCADA operations at MISO. This includes modeling inbound data received from customers and enabling outbound control signals sent by MISO. The system ensures reliable data exchange and real-time visibility across the grid. As HVDC systems are integrated, more detailed telemetries may be required, such as multiple MW readings, breaker statuses, and potential DC alarms. These could significantly increase the volume of data handled by the system. This growing data volume is an important consideration for maintaining system performance and scalability.

The operation of HVDC lines is influenced by how the market dispatch system is configured, such as whether it uses power dispatch or firing angle control, with dispatch targets typically set on a 5-minute interval. Currently, HVDC systems are not controlled through Automatic Generation Control (AGC) and therefore do not respond to 4-second regulation signals.

### **MODELING IMPROVEMENTS**

Since HVDC lines are modeled using a generation-load approach, this has eliminated the need to explicitly represent the HVDC link in steady-state reliability studies. However, in the future, HVDC line loss modeled as a contingency may be needed to better capture their potential impact on system stability.

Existing real-time applications such as State Estimator (SE), and Contingency Analysis (CA) already have capabilities to incorporate HVDC system modeling with minimal enhancement. For example, Constraint Logger (Clogger) supports sensitivity calculations within its existing framework and can model a controlled reduction in power transfer through HVDC, often referred as runbacks, to quantify the resulting relief on AC line flows. However, the ability to model a runback in studies is separate from the ability to execute it in real-time. Operational implementation would require that the HVDC facility support automated runback capability, as well as the installation of reliable, secure communications for real-time activation.

If HVDC facilities are used for regulation services or dispatched directly, the dispatch logic and modeling formulation need to be coordinated with application vendors. This might represent a substantial shift in operational monitoring and control practices. Additional monitoring capabilities may also be required, including PMUs, and angle controller visualization for real-time angle tracking.

### **ADVANCED HVDC MONITORING AND CONTROL**

An interregional HVDC link can play a critical role in improving frequency stability by providing fast balancing power support across asynchronous areas. Unlike conventional generators, which are constrained by mechanical inertia and governor response, HVDC systems can respond almost instantaneously to frequency deviations, thereby acting as a highly effective stabilizing resource.

A previous study evaluated how decentralized HVDC frequency controllers can improve system frequency response between the Eastern Interconnection (EI) and the Western Interconnection (WI) in the U.S. under a large disturbance.<sup>14</sup> The test scenario considered a simulated trip of a large generating unit in WI, resulting in a sudden drop in frequency. The decentralized controller provides fast response

---

<sup>14</sup> Frequency Response and Congestion Management using Multi-terminal HVDC overlay.  
<https://www.osti.gov/servlets/purl/1817447>



and shows improvement in both the lowest frequency point (nadir) and the settled final frequency. The control scheme increases power injection into the WI when its terminal frequency is low by utilizing the spinning reserves available in the EI to support the WI during the generation loss event.

From a centralized control perspective, HVDC fast power modulation can also be used for wide-area control. Assuming PMUs are installed at key locations in a network, their synchronized measurements can be leveraged in the control room to compute overall network stress in nearly real-time. The [technical appendix](#) formulates an Integral Square Bus Angle (ISBA) index that measures the overall network stress in terms of phase angle differences in the system.<sup>15</sup> A higher ISBA value indicates larger overall angle differences between buses, which means that the system is more stressed or closer to instability.

A response-based, centralized HVDC control scheme is a key application for such real-time indices. For example, if the rate of change of the phase angle difference exceeds a predefined threshold indicative of rapid angular divergence, the control center can automatically trigger a fast HVDC transfer (e.g., 500 MW). Such action would require advanced wide-area monitoring (e.g., PMUs) and automation can be done using machine learning algorithms trained to detect early signs of instability for fast control actions.

## CONTINGENCY IMPACTS

### CURRENT LANDSCAPE

One example of how an HVDC system can eliminate contingency constraints is the DC runback scheme implemented for Manitoba Hydro. The Manitoba Hydro system relies on HVDC bipoles to deliver bulk power from hydro-stations in northern Manitoba to southern Manitoba, where the power is then transferred to other Canadian provinces and into the MISO system through multiple AC tie lines. During periods of surplus generation in Manitoba, these AC ties become critical export paths. However, if one of the AC tie lines becomes overloaded or trips, the power it was carrying is redistributed onto the remaining parallel AC lines. This sudden redistribution can push those lines beyond their thermal limits, creating the risk of cascading outage across multiple tie lines. To mitigate this risk, Manitoba Hydro employs HVDC runback schemes that leverage HVDC's fast controllability to automatically reduce DC power injections into the AC grid during tie-line contingencies. Simulation of tie-line loss events with MISO have shown that, *without runback action*, post-contingency flows on the remaining parallel lines immediately exceed their emergency ratings after fault clearance.<sup>16</sup>

A sudden loss of an HVDC bipole can withdraw large amounts of power from the system, potentially representing the most severe contingency. For HVDC lead lines proposed to connect significant amounts of remote generation, a bipole trip may require an immediate subsequent trip of the remote generation because other facilities might not be in place to unload such generation. Depending on the magnitude of

---

<sup>15</sup>S. M. Rovnyak, M. N. Nilchi, D. W. Longbottom and D. C. Vasquez, "Angle stability predictive indices," 2012 IEEE Power and Energy Society General Meeting, San Diego, CA, USA, 2012, pp. 1-6, <https://doi.org/10.1109/PESGM.2012.6344976>

<sup>16</sup>N. V. Raju, A. D. Rajapakse, I. T. Fernando and D. Diakw, "Wide area synchrophasor measurements-based ac/dc integrated remedial action scheme for overload prevention," 15th IET International Conference on AC and DC Power Transmission (ACDC 2019), Coventry, UK, 2019, pp. 1-6, <https://doi.org/10.1049/cp.2019.0038>



such a generation trip, there could be adverse impacts to the interconnection including potential underfrequency load shedding (UFLS).

Although the NERC's 2004 Frequency Response Standard Whitepaper<sup>17</sup> is relatively dated, it provides insights that remain relevant to understanding frequency response of the Eastern Interconnection (EI). It reported an average EI frequency response of 3100 MW/0.1 Hz which means the first tier of UFLS at 59.7 Hz would be triggered at 9300 MW given the frequency declined from the nominal 60 Hz. Even with a reported declining rate of about 70 MW/0.1 Hz per year, UFLS vulnerability to a 2400 MW loss was projected after 34 years, which is a timeframe just around the corner today. While a merchant HVDC bipole trip resulting in a subsequent generation trip of 3000-5000 MW may or may not trigger UFLS today, it is prudent to study this possibility. NERC's whitepaper also did not foresee large-scale synchronous generators retirements, widespread IBR adoption, or high electronic load growth, all of which may worsen the issue, nor did it anticipate battery-based fast frequency response, which could help mitigate it.

Brazil's Rio Maderia project and Itaipu HVDC project (both consisting of two +/- 600 kV bi-poles each rated at 3,150 MW) connect remote generation resources relying on the HVDC links for injection into the system. When a bipole is blocked, these generations become electrically disconnected, causing a sudden drop in frequency in the receiving regions. On the other hand, for intra-regional or embedded HVDCs such as Brazil's Xingu bipoles ( $\pm 800$  kV each at 4,000 MW), a loss of the bipole causes an immediate redirection of power through the parallel AC corridors. This redirection leads to rapid increase in power-flow across long-distance loaded AC lines, potentially exceeding stability margins and causing voltage collapse.

To mitigate these effects, ONS system operators in Brazil have employed multi-tiered response strategies including an automatic run-up of remaining bipoles up to their short-time overload capacity, activation of Special Protection Schemes (SPS) to command generation tripping, and controlled load shedding.

## CONTINGENCY IMPACT ASSESSMENT

Contingencies involving large HVDC lines can create disproportionate operational impacts due to the sudden and significant loss of power transfer. When such line trips offline, system frequency declines rapidly, with the rate-of-change-of-frequency (RoCoF) depending on the magnitude of the outage and the available system inertia. In lower-inertia conditions, this can result in widespread IBR tripping, potentially triggering under-frequency load shedding (UFLS), and immediate activation of spinning reserves.

Under these types of disturbances, Area Control Error (ACE) spikes sharply, straining automatic generation control (AGC) systems and dispatch logic. Large shifts in power flow across tie lines and constrained interfaces can lead to thermal overloads and dynamic stability risks. Deliverability of contingency reserves becomes critical, particularly when reserve-sharing arrangements across Balancing Authorities are limited.

Under NERC BAL-002-3, the HVDC line may be classified as a single balancing contingency if its full loss is considered credible, requiring reserves equal to its full rating. This classification can significantly increase

---

<sup>17</sup> <https://studylib.net/doc/8926789/frequency-response-standard-whitepaper>



reserve procurement requirements and operational costs. The MSSC must be determined and updated accordingly, and the value communicated to the Contingency Reserve Sharing Group (CRSG) as required under BAL-002-3 R1 and R2. MISO's current MSSC is 1732 MW. An annual review of MSSC is completed during November/December each year.

The loss of a large HVDC line can degrade voltage support and alter power flow distributions across the network. Inertia conditions may be particularly stressed during periods of low load or high IBR penetration. In multi-BA or multi-ISO environments, as is the case across the Eastern Interconnect, the reserve response to such a contingency must be coordinated and verified in advance. Real-time evaluation should confirm whether the event leads to ARS (automated reserve sharing) triggers or affects use of external asynchronous resources (EARs), such as those seen in Manitoba-related events. For instance, run back schemes should be coordinated with external resource owners.

### **CONTINGENCY IMPACT RECOMMENDATIONS**

To mitigate the risks associated with HVDC contingencies, several measures can be taken. As a part of the contingency management procedure, MISO should continue to update the MSSC and contingency reserve requirements as system conditions evolve to ensure reliability. As HVDC penetration increases, MISO should assess the risk of contingency reserve cost increases and evaluate opportunities to mitigate these increases through reserve sharing agreements or alternative cost allocation processes.

Within the post-contingency timeframe, it is necessary to assess both transient stability and dynamic response of the system. Frequency response losses must be quantified, and any generation redispatch or additional load shedding actions identified. Existing remedial action schemes (RAS) or special protection systems (SPS) relevant to the HVDC facility should be reviewed to ensure appropriate triggering and containment logic.

Market systems may need to assess whether sufficient ramping and reserve capability exists post-contingency. Changes in reserve obligations or delivery timelines may occur depending on how the event is classified and responded to.

Finally, operational readiness must be ensured. Control room operators should be trained for HVDC-specific outage scenarios, including appropriate notification and escalation procedures. Post-event analysis and regulatory filings may be required depending on the size, cause, and consequence of the event.

### **RELIABILITY COORDINATION**

To support the reliability of System Operations, MISO's current outage coordination process, as outlined in BPM-008, provides a robust framework for planning, analyzing and managing transmission and generation outages through tools such as CROW and AFC evaluations. However, as the system footprint increasingly integrates large-scale HVDC facilities, the traditional outage coordination framework faces new challenges. Unlike conventional AC lines, HVDC outages can cause high-magnitude and complex impacts that extend beyond thermal constraints. A bipole outage, for instance, may represent several thousand megawatts of sudden power transfer loss or redirection, significantly influencing voltage stability, inter-area oscillations, and reserve deployment. Moreover, HVDC systems involve converter stations, DC cables, and associated reactive support equipment, each of which may require maintenance



or experience partial outages that needs to map neatly into existing AC outage categories. Partial outage or derate causes temporary reduction in the transfer capability that affects operations and must be represented accurately in operational and planning models.

## **RELIABILITY COORDINATION RECOMMENDATIONS**

As HVDC systems become operationally flexible, outage coordination will need to increasingly incorporate functional performance and stability assessments. MISO could evaluate more granular representation of partial outages or de-rates during outage coordination. Transmission operators must submit planned maintenance outage schedules that include reactive device outages related to HVDC facilities. All active outage records, including those for HVDC related facilities, will be used in MISO's AFC calculation process and posted to NERC System Data Exchange (SDX) system for use in congestion management. Operational planning needs to increasingly incorporate specialized contingency screening, including NERC TPL-001 standard P6 and P7 contingencies to include the loss of single pole and bipole HVDC due to a short-circuit fault.

The maintenance of HVDC and its components must be monitored. As for example, CAISO monitors the maintenance practices of transmission facilities, including HVDC systems, in accordance with Appendix C, Section 4 of the CAISO Transmission Control Agreement (TCA). This section establishes the availability measures used to evaluate the effectiveness of transmission owner's maintenance programs. For HVDC facilities, these measures include indices such as the Annual Average Forced Outage Frequency, and Annual Average Forced Outage Duration, calculated using forced outage data. Schedules outages and any events not classified as forced outages are excluded from these calculations. Transmission owners are required to include descriptions of maintenance activities for DC components within their stations in their annual maintenance reports. An example of such reporting is the Trans Bay Cable annual net availability report, which provides data on overall HVDC system performance.<sup>18</sup>

---

<sup>18</sup> <https://www.caiso.com/documents/trans-bay-cable-transmission-availability-report.pdf>



## 4 Resource Adequacy Impact Assessment

Resource adequacy (RA) refers to the ability of the bulk electric system to serve electricity demand while also providing enough excess supply to achieve a threshold level of grid reliability. One such measure of reliability is the industry-accepted 1-day-in-10 years Loss of Load Expectation (LOLE) target. This section provides an overview of how External Resources and transmission are currently treated in MISO’s resource adequacy construct, updates which are currently being considered by MISO, and additional options that could be explored to represent the impact of HVDC-enabled facilities on resource adequacy.

### Key Insights

- **External Resources are accredited in the PRA:** Existing rules allow for External Resources transferring power into MISO to participate in the MISO PRA
- **LOLE model is transmission-less:** The model includes and recognizes estimates of imports and exports between Regions, External Region interactions with the MISO system not explicitly modeled

### Recommendations

- **Resource adequacy treatment of external resources, including those delivered via HVDC:** MISO should collaborate with stakeholders to clarify how external resources, including those delivered by HVDC-enabled firm transmission, are modeled and participate under MISO’s current resource adequacy construct.
- **Accreditation enhancements for external resources:** MISO should evaluate updates to external resource accreditation to improve alignment with the Direct Loss of Load/resource adequacy hours approach.
- **Representation of transmission in resource adequacy risk modeling model:** MISO could evaluate approaches to incorporating transmission, including HVDC facilities, into resource adequacy risk modeling.

### MISO RESOURCE ADEQUACY CONSTRUCT OVERVIEW

In the MISO footprint, the primary responsibility for achieving resource adequacy resides with Load Serving Entities (LSE) with oversight by Relevant Electric Retail Rate Authorities (RERRA), as applicable by jurisdiction. MISO facilitates these efforts by administering its Open Access Transmission, Energy and Operating Reserve Markets, tariff-defined Resource Adequacy Requirements (RAR) and the Planning Resource Auction (PRA), which LSEs use to demonstrate their ability to contribute to resource adequacy and provide a sufficient margin of excess supply. Following FERC’s acceptance of MISO’s Seasonal Resource Adequacy Construct and Seasonal Accredited Capacity filing, MISO now sets the LOLE-based Planning Reserve Margins on a seasonal basis for each PRA.<sup>19</sup>

MISO facilitates the annual PRA where resources offer capacity (MW) that can be used to meet the demand and reserve obligations of LSEs that are determined from a combination of their peak demand

<sup>19</sup> Filed in August 2022, effective with MISO’s Planning Year 2023-2024 PRA.



forecasts and the modeling results of the LOLE study. In preparation for the annual PRA, MISO conducts a probabilistic LOLE study to determine Resource Adequacy Requirements for the upcoming Planning Year. The LOLE study calculates the Planning Reserve Margin (PRM) to achieve the annual LOLE target, as well as minimum LOLE targets by season. These requirements are identified on a seasonal basis within MISO. In addition to the PRM, Local Reliability Requirements for each Local Resource Zone (LRZ) are determined for each season of the upcoming Planning Year and represent the capacity that must be held internally in each zone to achieve the reliability requirement.

The LOLE study assumes no transmission limitations within the model and does not directly model transmission. The MISO Tariff explicitly excludes transmission considerations in the modeling that sets capacity requirements.<sup>20</sup> Although transmission is not considered in the LOLE analyses, import and export capabilities with external systems are considered in MISO's PRA indirectly through both firm and non-firm external support. Additionally, Capacity Import Limits (CIL) and Capacity Export Limits (CEL) are considered when setting the LRZ requirements in the PRA.

Under MISO's current resource adequacy construct, all Planning Resources that qualify to participate in the PRA will have a Seasonal Accredited Capacity (SAC) value determined by MISO. Planning Resources consist of Capacity Resources, Load Modifying Resources, and Energy Efficiency Resources. Capacity Resources consist of Generation Resources, Electric Storage Resources, External Resources, and Demand Response Resources. Load Modifying Resources consist of Behind the Meter Generation and Demand Resources. Energy Efficiency Resources<sup>21</sup> are resources registered with MISO that permanently reduce electricity Demand.

MISO does not determine explicit capacity credit for transmission lines (both HVAC and HVDC). External Resources can participate in the MISO PRA regardless of whether they are transferring power into the MISO footprint through the HVAC or HVDC lines provided they meet the qualification criteria as documented in MISO's Resource Adequacy [Business Practices Manual BPM-011](#).

## **EXTERNAL RESOURCES IN THE RESOURCE ADEQUACY CONSTRUCT**

MISO's resource adequacy construct allows firm/contracted resource to earn capacity credit in the PRA. Transmission enables internal and external resources to participate in the MISO capacity market but transmission alone does not earn capacity credit. Instead, transmission enables the resources utilizing it to participate in the PRA and the MISO Energy Markets. No RTO in North America currently allows transmission lines to earn capacity credit. Every RTO only accredits Resources. A key consideration in the evolving capacity accreditation practices is whether - and under what circumstances - transmission facilities themselves should be eligible for earning capacity credit. Implementing such a change would represent a significant shift from the current approach, which only accredits Resources utilizing those facilities.

MISO requires capacity cleared in the PRA to be dedicated exclusively to the MISO Region. The same generation resource cannot earn capacity credit in two different RTO Regions for the same portion of the

---

<sup>20</sup> MISO Tariff 68A.2 - Planning Reserve Margin Analysis

<sup>21</sup> MISO filed to remove Energy Efficiency Resources from the PRA in FERC Docket No. ER26-148 on October 15, 2025.



resource. In addition to the requirement that committed capacity be exclusive to MISO, a demonstration of ownership or contractual obligation is required.

Without an attestation that generating capacity is proven and dedicated to MISO, significant modeling and external coordination would be required to have a reasonable expectation of expected reliability. In addition to modeling and coordination concerns, allocating capacity credit to transmission lines would require some method to separate the reliability benefits provided by transmission lines from the reliability benefits provided by generators using the transmission lines. This methodology could be complicated even if it were determined to be feasible and would require additional processes to avoid double-counting expected reliability benefits.

Although MISO does not currently accredit transmission, External Resources can earn accreditation and participate in the PRA based on ownership (direct or joint), firm contracted capacity, or using a slice-of-system approach. Each of these frameworks provides a potential option for HVDC-enabled external resources to participate directly in the MISO PRA.

- i. Market Participants can register External Resources that they have either direct ownership or joint ownership of for one or more seasons in the PRA. If owned, a Market Participant may also choose to register an External Resource in MISO's Network and Commercial Models through a pseudo tie.
- ii. An External Resource registration that is backed by a Power Purchase Agreement (PPA) is often referred to as firm contracted capacity. To register this type of External Resource, the Market Participant would need to provide MISO with the proper documentation, including but not limited to a copy of the PPA, that demonstrates the entitlement to the specific amount of capacity they are seeking to register and the specific generator(s) comprising the External Resource registration.
- iii. A Market Participant may also register a pool of two or more generators as a slice-of-system External Resource. Slice-of-system External Resources that participate in MISO are registered through a type of PPA which guarantees seasonal or annual capacity commitments from a pool of resources physically residing in an external system. The requirements of a standard PPA described in provision (ii) would also apply to a slice-of-system PPA. Additionally, a slice-of-system PPA may involve a diversity exchange arrangement wherein, during specific months of the year, capacity from MISO-internal resources is exported to support an external system and vice-versa during other specified months. In the case of diversity exchange agreements, the MISO-internal capacity being exported is excluded from accreditation in applicable seasonal auction(s) of the PRA as it would be unavailable to serve MISO load.

External Resources are referred to as Firm External in the LOLE Study Report and must meet the following requirements:

- Seasonal Accredited Capacity (SAC) is based on seasonal Generator Verification Test Capacity (GVTC) and seasonal 3-year average forced outage rates, if GADS-reporting. If a non-GADS resource, SAC is based on historical availability during MISO system coincident seasonal peak hours.



- Requires firm transmission to the MISO border and from the border to an identified MISO sink.

Firm External Resources are accounted for as a line item in the seasonal PRM calculations. Exports to other areas (such as PJM and SPP) are accounted for in the LOLE model and in the Planning Resource Auction based on PJM's Reliability Pricing Model (RPM) as well as the MISO Independent Market Monitor (IMM) exclusion list.

External resources that clear the PRA have a Must Offer requirement in the Day-Ahead Energy Market as outlined in Section 6.1.4 of [MISO's Resource Adequacy Business Practices Manual \(BPM 011\)](#).

External Resources that clear the PRA get the External Resource Zone (ERZ) pricing, unless they are a Border External Resource or a Coordinating Resource. If a Border External Resource or a Coordinating Owner External Resource (Manitoba Hydro), they would get the ACP of the sink zone and are treated as if they were an internal Resource in the model.

A Border External Resource is an External Resource that:

- has direct interconnection facilities to a substation that contains the terminal of a transmission line under the Transmission Provider's functional control;
- will schedule in response to notification by the Transmission Provider during a declared Energy Emergency solely from unit(s) connected to such substation; and,
- whose Unforced Capacity offered into MISO may be accommodated on those transmission line(s) under the Transmission Provider's functional control.

The LOLE probabilistic analyses for Planning Year 2026-2027 assumed between 1.0 – 1.3 GW of firm imports, depending on the season, as shown in Table 3-16 of the [Planning Year 2026-2027 Loss of Load Expectation Study Report](#).

## TREATMENT OF TRANSMISSION IN THE LOLE MODEL

The current LOLE model does not include the limitations that transmission imposes on the transfer of power across the MISO footprint. MISO incorporates non-firm external support as seasonal probabilistic distributions within the LOLE Model. Non-firm support is estimated using historical Net Schedule Interchange (NSI) and removes any participating firm external capacity as well as firm exporting capacity as identified by the Independent Market Monitor and PJM's Reliability Pricing Model (RPM).

The non-firm support represents the amount of non-firm energy MISO could reasonably expect on a real-time basis to meet electricity demand while accounting for the transmission constraints between MISO and external areas, as well as the amount of excess available energy that external areas would be able to offer MISO after serving the external Region.

Non-firm support is not a line item in the PRM calculations but is accounted for when determining the adjustment needed to reach seasonal LOLE criteria. The inclusion of non-firm support in resource adequacy modeling results in lower seasonal PRMR as it offsets the need for a more positive adjustment to capacity in the model to reach seasonal LOLE criteria.

HVDC transmission today can enable Firm External Resources to participate in the MISO PRA for capacity credit and can additionally provide non-firm support contributing to overall reliability. Under the



current construct, an HVDC line does not need to be explicitly included if the HVDC-enabled External Resources are included in the model. Estimating the reliability contributions of an HVDC line, independent of the resources involved, would likely require incorporating transmission into the LOLE model, some knowledge of how the capacity is showing up in energy markets, and explicit modeling of External Regions in the LOLE model. Inclusion of these factors would increase the complexity of the LOLE model.

MISO is exploring whether and how to incorporate the effects of transmission in the LOLE model, which is expected to add significant complexity to the model. MISO anticipates that HVDC and HVAC transmission may need similar considerations to be included in the model.

## A NEW ACCREDITATION FRAMEWORK

Beginning in PY 2028-2029, MISO's DLOL methodology for accrediting all resources (except Load Modifying Resources and External Resources) measures a resource's availability when reliability risk is greatest. Direct Loss of Load (DLOL)-based accreditation is based on the modeled capabilities of Resource Classes and is allocated by an evaluation of the historical performance of specific resources within a Resource Class.

DLOL accreditation will be determined in a two-step process:

- The Resource Class-level step sets the "size of the pie" for each of the thirteen Tariff-defined Resource Classes which is determined using probabilistic risk modeling by measuring resource availability during simulated high-risk hours.
- The Resource-level step determines how large each "slice of the pie" is by evaluating a specific resource's historical availability during historical high-risk hours. Resource Class-level accreditation is then allocated to each individual Resource within a given Resource Class.

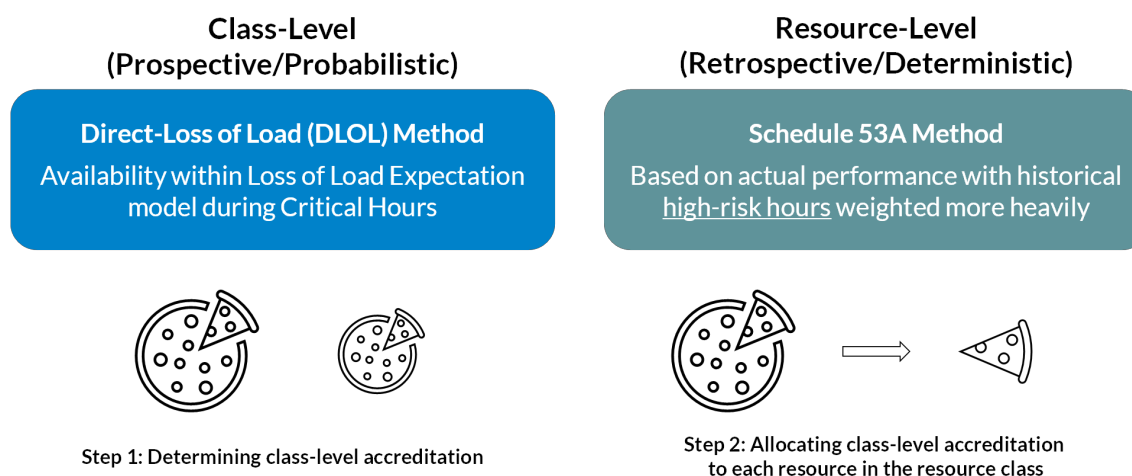

Figure 10: DLOL Accreditation

Although the accreditation of External Resources was not included in the recent reforms adopting DLOL accreditation, MISO plans to begin an evaluation of External Resource accreditation as a next step in



Resource Accreditation Reform. In collaboration with stakeholders, MISO plans to evaluate External Resource accreditation in the PRA to align with the DLOL framework that was approved by FERC and is going into effect starting with Planning Year 2028-2029. Consideration of HVDC-enabled capacity will be an important part of this work.

## RESOURCE ADEQUACY MARKET DESIGN

MISO has explored a wide range of potential accreditation approaches for new HVDC-enabled resources. MISO understands and acknowledges that the new HVDC-enabled resources can contribute to reliability and resource adequacy of the MISO system. However, incorporating HVDC into existing resource adequacy processes or developing any new processes cannot be isolated from a holistic assessment of overall HVDC integration.

As described above, External Resources today can participate as Firm External Resources. MISO has identified a few options for incorporating HVDC transmission into the resource adequacy construct. Table 2 lists options that would need to be evaluated before figuring out changes to the design for HVDC’s role in the MISO resource adequacy construct, specifically accreditation and reliability requirements calculations. Although MISO is not actively exploring any of these options at this time, this list is intended for discussion purposes. Any options would need to be evaluated for complexity, feasibility, accuracy, and other factors. These options are presented in order of increasing complexity, with the first items on the list being available with little to no changes to current systems, and the latter ones requiring the largest potential changes to MISO systems and models.

Option	Summary	Anticipated Considerations
Continued use of External Resource Accreditation	Credit firm external resources, non-firm imports are socialized	Resource Class definitions may be needed for HVDC-enabled External Resources
Credit HVDC line based on performance during resource adequacy hours	HVDC line modeled and accredited separately from other non-firm external support	Potentially difficult model changes needed to differentiate the impact of HVDC assistance from other external support
Expand Zonal Deliverability Charge (ZDC) Hedges to include merchant-built transmission	Allowing merchant HVDC to have an option similar to ZDC-hedge in MISO Tariff Section 69A.7.7(b)	ZDC hedges have not been exercised and are currently only available to LSEs providing benefit for investment and would require stakeholder discussion
HVDC Direct Loss of Load (DLOL)/Resource Adequacy Hour accreditation	HVDC-enabled assistance accredited based on DLOL accreditation design	Potentially requires detailed modeling of and coordination with External Regions

Table 1: Evaluation of options for HVDC role in the MISO resource adequacy construct

## CONTINUED EXTERNAL RESOURCE ACCREDITATION

The default option is to continue with MISO’s current market design with no major changes to the construct. Under the status quo, HVDC lines are not provided with explicit capacity credit but act to



enable firm and non-firm support from external areas. As a part of MISO's evaluation of External Resource accreditation reforms there still may need to be some adjustments needed due to HVDC-enabled Resources such as new Resource Class definitions for external classes.

### **CREDIT HVDC LINES BASED ON PERFORMANCE DURING RESOURCE ADEQUACY HOURS**

Another option could provide accreditation to HVDC lines based on performance during Resource Adequacy (RA) hours. Under this option, the expected reliability contribution from an HVDC line would be evaluated based on the power delivered by the HVDC lines during challenging operational hours, like how performance for internal Resources are calculated under Schedule 53.<sup>22</sup> HVDC lines would not be explicitly included in the model, but their impact would have to be carved out from non-firm import assistance.

No data would be available for the first year of operation for new lines which would require developing a default methodology for new HVDC lines. It could also prove difficult to estimate accreditation in forward-looking assessments without sufficient operating histories. An alternative would be for new lines to start with no accredited value until sufficient historical data is available to measure historical performance.

Although the impact on the model may not be large, model modifications would be needed to differentiate the impact of HVDC assistance from other external support (e.g., a reduction of expected assistance from non-firm imports). Additional challenges include how the line will be registered and operated, as well as how Resource Adequacy (or capacity) obligations would be assigned.

### **EXPAND ZDC HEDGES TO INCLUDE MERCHANT-BUILT TRANSMISSION**

The current tariff allows an LSE to benefit from transmission investment that is shown to alleviate transmission congestion and, as a result, lower internal zonal capacity obligations in the form of a Zonal Deliverability Charge (ZDC) Hedge. A ZDC Hedge allows protection against zonal price separation in instances where the Auction Clearing Price (ACP) of the LRZ where the Resource is physically located is less than the ACP of the exporting LRZ whose PRMR the Resource is being used to meet. ZDC Hedges have not been exercised historically and are currently only available to LSEs. Expanding this concept to merchant-HVDC investments would require further evaluation and stakeholder discussion.

### **HVDC DIRECT LOSS OF LOAD (DLOL) ACCREDITATION**

HVDC assistance could also be evaluated under the DLOL framework by using modeled transfers. This approach would require modeling of the external world in the LOLE model. At a minimum, it requires creating "bubbles" to represent neighboring regions and their capacity transfers to MISO. This would require collection and generation of data for those regions, including but not limited to, a list of resources (type, capacity, performance, maintenance, etc.), wind/solar shapes, load hourly shapes, and load

---

<sup>22</sup> Under Schedule 53 and 53a, performance during resource adequacy hours is used to distribute the Resource Class DLOL accreditation among individual resources. This is captured in Figure 10 (DLOL Accreditation). While that would remain unchanged for internal resources, this option proposes to calculate the average contribution of each HVDC. HVDC lines would likely not have a Resource Class accreditation determined through the LOLE model.



forecasts. This more detailed representation of the MISO neighbors would result in a significant increase in model complexity, and effort needed to update and maintain the model every year.

A benefit of this increased modeling complexity is forward-looking assessments that could estimate the impact of those imports. Those updates would also be more complex because they would require representing future portfolios and scenarios for the modeled neighboring regions.

As with other options, introducing DLOL accreditation for assistance from external regions may require coordination and tradeoff discussions with neighbors to ensure that MISO and its neighbors will get the expected benefit when either system is at a high risk for shedding load. External Systems may need to be fully incorporated into the model, which would greatly increase the complexity of reliability modeling. Coordination agreements may be required to ensure reliability across regions and may require adding transmission to the current transmission-less model. Benefits provided by Resources and by transmission would also need to be separated from one another.

## CONCLUSION AND NEXT STEPS

Several merchant HVDC transmission lines are being proposed for interconnection to the MISO transmission system. This section provides an overview of External Resource accreditation in MISO's resource adequacy construct, next steps in the reform of the construct, and additional options that could be explored to assess the impact of HVDC facilities on resource adequacy.

HVDC-enabled resources will need to be accounted for in the MISO resource adequacy construct by either utilizing existing processes or through the development of new processes. However, incorporating HVDC into existing resource adequacy processes or developing any new processes cannot be isolated from a holistic assessment of overall HVDC integration.

MISO has considered several mechanisms to incorporate HVDC transmission into the resource adequacy construct which are provided herein as a starting point for discussion. Many of the options under consideration could require significant changes to MISO's Loss of Load Expectation (LOLE) modeling as well as coordination and agreements with neighboring regions. As mentioned previously, MISO is planning to enhance the existing External Resource accreditation process as the next step in its Resource Accreditation Reform effort. HVDC-enabled resources will be a part of that evaluation effort. Additional changes to the resource adequacy construct would need to be evaluated and prioritized before moving forward with further evaluation.

Future work will focus on:

- Providing clarification regarding how External Resources, including those delivered by HVDC-enabled firm transmission, are modeled and participate under MISO's current RA construct.
- Evaluating accreditation of external resources to improve alignment with the Direct Loss of Load / Resource Adequacy (RA) Hours approach.
- Evaluating methods for incorporating transmission lines, including HVDC, into resource adequacy risk modeling.



## 5 Interconnection of Merchant HVDC Lines

This section discusses the MHVDC Interconnection Process only and is not applicable to HVDC transmission considered internally in MISO's Transmission Expansion Planning process. Tariff Attachment GGG describes the MHVDC Transmission Connection Procedure (MHCP), which was implemented in 2018. This procedure governs the method by which a Merchant HVDC transmission line external to MISO may connect to the Transmission System.

### Key Insights

- Several Merchant Interregional HVDC projects are being proposed in MISO MHVDC queue.
- Commercial value of Merchant Interregional HVDC depends on securing the right products and approvals, such as:
  - Injection and/or Withdrawal rights
  - Deliverability
  - Limited-Operations provisions & interim use, etc.
- MHVDC needs strong interconnection planning modeling and coordination among all impacted parties- associated RTOs, interconnection customers, and transmission owners. etc.

### Recommendations

- **Improvements to MISO Attachment GGG Process:** Stakeholders have requested clarification and streamlining of interconnection processes for Merchant HVDC facilities. These requests include the use of TSRs via Module B for Injection/Withdraw rights and the development of preliminary MHVDC study procedures to better service customers before the full Att. GGG studies. MISO is making Tariff language changes to Attachment GGG, updating the MISO MHVDC interconnection process, and making Limited Operation clarifications for interim periods on qualified MHVDC projects and will continue to engage with stakeholders on these issues through the IPWG and PAC.
- **HVDC Business Practice Manual:** Stakeholders have requested that MISO create a dedicated BPM to enhance clarity, efficiency, and alignment with Tariff provisions for the MHVDC interconnection process. MISO is creating an MHVDC BPM focusing on MHVDC application, application modification, application withdrawal, study scope, process timelines, study requirements, affected system studies, and Pre-TCA considerations.

MISO has received several interregional MHVDC connection requests across multiple seams since 2019. Operationalizing each of these requests will require strong interconnection planning modeling and close coordination between MISO, the MHVDC interconnection customer, impacted Transmission Owners, and neighboring Regional Entities.

### CURRENT STATE OF MISO'S MERCHANT HVDC INTERCONNECTION PROCESS

Figure 11 below shows the major steps of the MHVDC Connection Procedure, which begins with a Transmission Connection Request (TCR) and ends with an executed Transmission Connection Agreement (TCA). Applications for MHVDC Transmission Connection Service are processed on a first-come, first-serve basis.

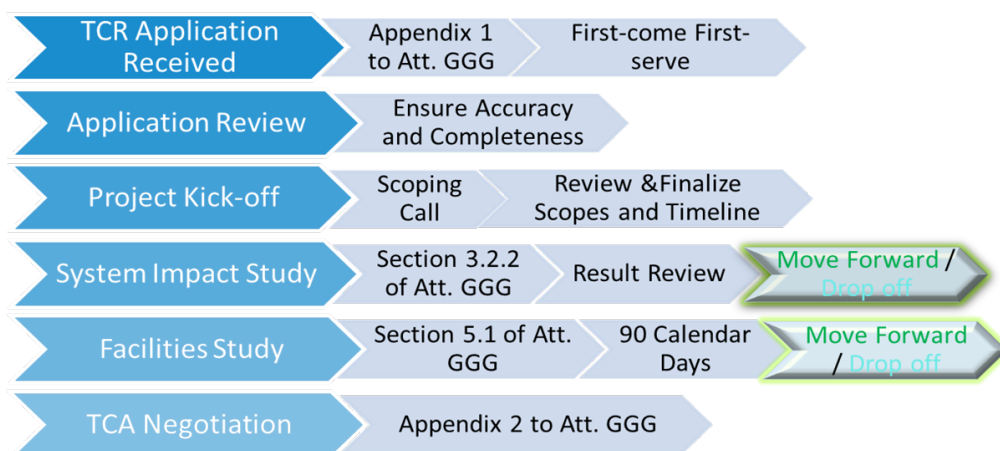

Figure 11: MHVDC Connection Procedure Steps

### ACTIVE PROJECTS IN MISO'S MHVDC INTERCONNECTION QUEUE

MISO's MHVDC Interconnection Queue currently contains the following three projects, all of which are targeting commercial operation in the 2030-2032 timeframe:

- North Plains Connector (NPC) – A proposed bi-directional HVDC transmission project in the Northern Plains region intended to facilitate transfer capability between the western and central U.S. grids, with a proposed interconnection into the MISO footprint.
- Grain Belt Express (Phase 1) – A proposed multi-phase HVDC transmission project designed to deliver energy from the central Plains region into the Midwest, with an announced future extension concept to enable delivery farther east.
- SOO Green – A proposed underground HVDC transmission project intended to move power between Iowa and northern Illinois, with planned interconnections in the MISO and PJM regions.

Project descriptions are based on publicly announced information; specific interconnection request configurations, POI details, study status, and queue positions may be confidential and are not reflected here.

All MHVDC projects submitted to MISO, including those completed, withdrawn, active, or queued, are publicly disclosed on [MISO's website](#).

### MHVDC PROCEDURES IN OTHER ISO/RTOS

The following is a short summary of policy notes on MHVDC processes hosted by other regional entities (SPP, NYISO, and ERCOT) based on publicly available information.

#### Southwest Power Pool (SPP)

- SPP allows merchant HVDC, with structured interconnection and service request processes.
- SPP's Tariff Attachment AR governs this MHVDC interconnection process.

Recent revisions of the process require demonstration of site control, more formal milestone tracking, and clarity around modifications (very similar in spirit to pending MISO Attachment GGG improvements).



## New York ISO (NYISO)

- NYISO has a special Interconnection Service Agreement (ISA) process for MHVDC facilities.
- Deliverability studies are fully integrated into the Class Year process.
- MHVDC projects are treated under the developer-funded interconnection model, and the developer is responsible for any required transmission system upgrades.
- Limited operations (e.g., pre-commercial testing) are handled case-by-case but must comply with NYISO's Tariff and Operating Procedures.

## Electric Reliability Council of Texas (ERCOT)

- ERCOT requires that most HVDC projects must demonstrate no adverse operational impact on ERCOT system reliability.
- All costs are developer-funded; there is no network cost allocation.
- MHVDC ties are typically operated in a controlled flow mode to prevent unscheduled interchange.

## MERCHANT HVDC INTERCONNECTION FUTURE STATE - PROCESS IMPROVEMENTS

After gaining experience with Merchant HVDC transmission connection procedures outlined in MISO's Tariff Attachment GGG, both MISO and stakeholders have identified opportunities for improvement and efficiencies to benefit future MHVDC projects. This will include changes in both the Tariff and Business Practice Manuals, and is captured as "Attachment GGG Improvements" on the MISO Dashboard in [Issue PAC-2024-6](#).

The general workplan for improvement is expected to proceed in three phases, subject to change and stakeholder feedback, with expected completion by the end of 2026.

- Phase 1 includes creating a new Business Practice Manual dedicated to the current process, updating the MHVDC application process, clarifying withdrawal rights, and initiating a limited operations framework for MHVDC projects that require network upgrades. This work is actively in progress.
- Phase 2 includes clarification of Necessary Upgrade and Network Upgrade definitions within Attachment GGG, and other clarifications within the Transmission Connection Agreement (TCA).
- Phase 3 will include changes to Module B Transmission Service provisions to consider MHVDC injection and withdrawal rights. Currently, MHVDC projects seeking injection rights are limited to requesting these in the Generation Interconnection queue via Attachment X.



## 6 Transmission Expansion Planning of Intra-regional HVDC Lines

Any future intra-regional HVDC solutions selected in a future regional planning process will likely require automatic controls, which could include phase angles controls that simulate the performance of a proxy AC line, or the line could be dispatchable and co-optimized with resource outputs via the security constrained economic dispatch algorithms that clear the real-time market on a five-minute basis. Other control configurations could be explored as well.

### Key Insights

- For lines longer than 400 miles in length, HVDC tends to have a lower cost per MW mile.
- For lines shorter than 250 miles in length, EHV AC tends to have a lower cost per MW mile.
- For lines in the 250-50-400-mil length, the cost of HVDC vs. EHV AC should be determined on a case-by-case basis.
- For scenarios where granular flow control capability is desired, HVDC lines have an advantage.
- For scenarios where natural flow response is desired, EHV AC lines have an advantage.
- VSC HVDC lines can potentially provide dynamic reactive power and other ancillary benefits, but such benefits only exist if not already available from other nearby facilities such as conventional synchronous generation over inverter-based generation that must be installed to facilitate resource interconnections.

### Recommendations

- **Test modeling and performance of PROMOD HVDC simulation capabilities:** As a medium priority, MISO should test the modeling and performance of the dispatchable and co-optimized HVDC capability of PROMOD to ensure it is an acceptable proxy for the dispatchable HVDC solution to be developed by the market side.
- **Investigate feasibility of AC line emulation controls:** MISO could further investigate the feasibility of AC line emulation controls as an option for future regional HVDC lines where AC response is desired, but the line length is too long for an AC line.

### MISO CURRENT STATE

Intra-regional HVDC lines represent lines that are entirely within the MISO region and are planned by MISO. Any intra-regional HVDC line that is planned by MISO will be under full functional control of MISO including full five-minute dispatch control. For MISO to plan an intra-regional HVDC line, the ability to dispatch and co-optimize an intra-regional HVDC line must be developed, tested, and approved by the MISO markets and operations organizations as a valid option.



## MISO FUTURE STATE

### TRANSMISSION CAPACITY IMPACTS OF LINE LENGTH FOR EHV AC VS. HVDC LINES

The main consideration when comparing EHV-AC solutions versus HVDC solutions is the cost per MW-mile of each choice. Therefore, it is important to understand the limits of EHV AC lines vs. HVDC lines and how these loading limits are impacted by line length.

The capacity of an HVDC line is typically limited by two considerations whereas the capacity of an EHV AC line is typically limited by three considerations.

### THERMAL LIMITS

Both HVDC lines and AC lines are limited by thermal limits, which represent the maximum operating temperatures for all load carrying electrical facilities and equipment. For HVDC lines, this includes the line conductors, the converters at each terminal and the AC terminal equipment at each terminal. For EHV AC lines, this includes the line conductors as well as AC terminal equipment at each terminal. Thermal limits are not a function of line length for either HVDC lines or AC lines.

### MAXIMUM POWER TRANSFER LIMITS

HVDC and AC lines are also limited by a maximum power transfer limit that is unique to each line. For AC transmission lines, the maximum power transfer limit of a line is typically based on the following equation which approximates the real or active power flow on an AC transmission line:

$$\text{Maximum Power Flow (Per Unit or MW)} = |V_S||V_R| / |X_L|$$

where  $V_S$  = Voltage at Sending Terminal in per unit or  $kV_{\phi\phi}$

$V_R$  = Voltage at Receiving Terminal in per unit or  $kV_{\phi\phi}$

$X_L$  = Series reactance of line in per unit or Ohms

The equation above implies that the maximum power flow through an AC transmission line is inversely related to the series reactance of the line, and thus inversely related to the length of the line. Figure 12 illustrates the maximum power transfer limit of various AC EHV lines versus line length:

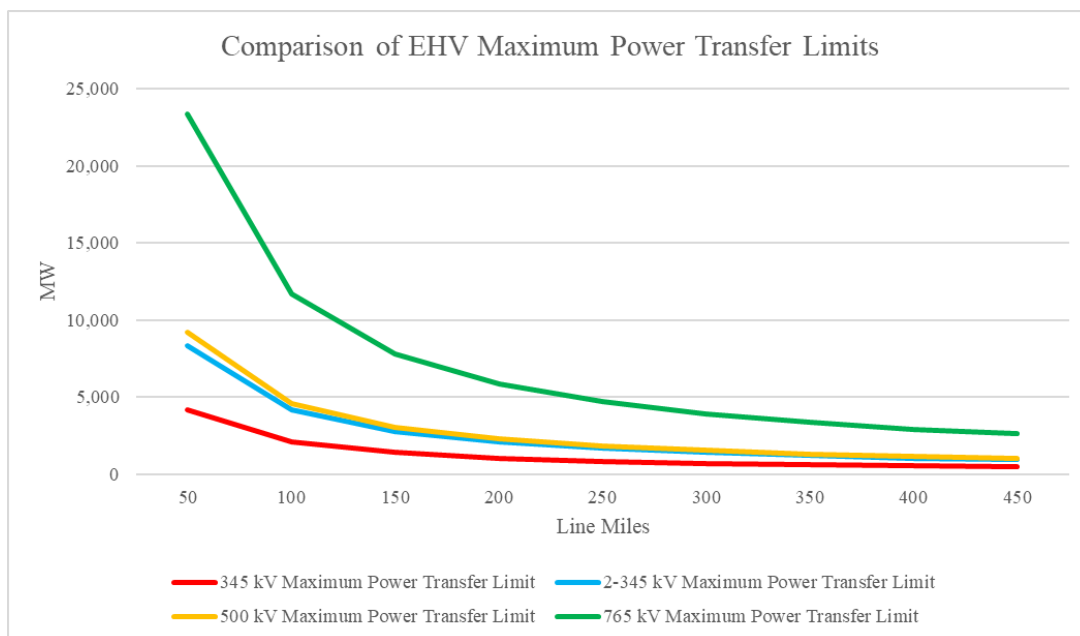

**Figure 122. Comparison of Extra High Voltage Maximum Power Transfer Limits by Line Rated Voltage**  
**NOTE: The graph assumes that the line terminals are infinite buses.**

For HVDC bi-pole lines, the maximum power transfer limit of a line is typically based on the following equation which approximates the power flow on an HVDC transmission line when the terminal HVDC voltages are constrained to +/- 5% of the nominal HVDC voltage level:

$$\text{Maximum Power Flow} = 2 * [1.05V_N][1.05V_N - 0.95V_N] / R_L = 0.21V_N^2 / R_L$$

where  $V_N$  = Nominal HVDC Voltage in per unit or  $kV_{LG}$

$R_L$  = Series resistance of line in per unit or Ohms

The equation above implies that the maximum power flow through an HVDC transmission line is inversely related to the series resistance of the line, and thus inversely related to the length of the line. Figure 13 illustrates the maximum power transfer limit of various hypothetical +/- 640 kV HVDC lines versus line length:

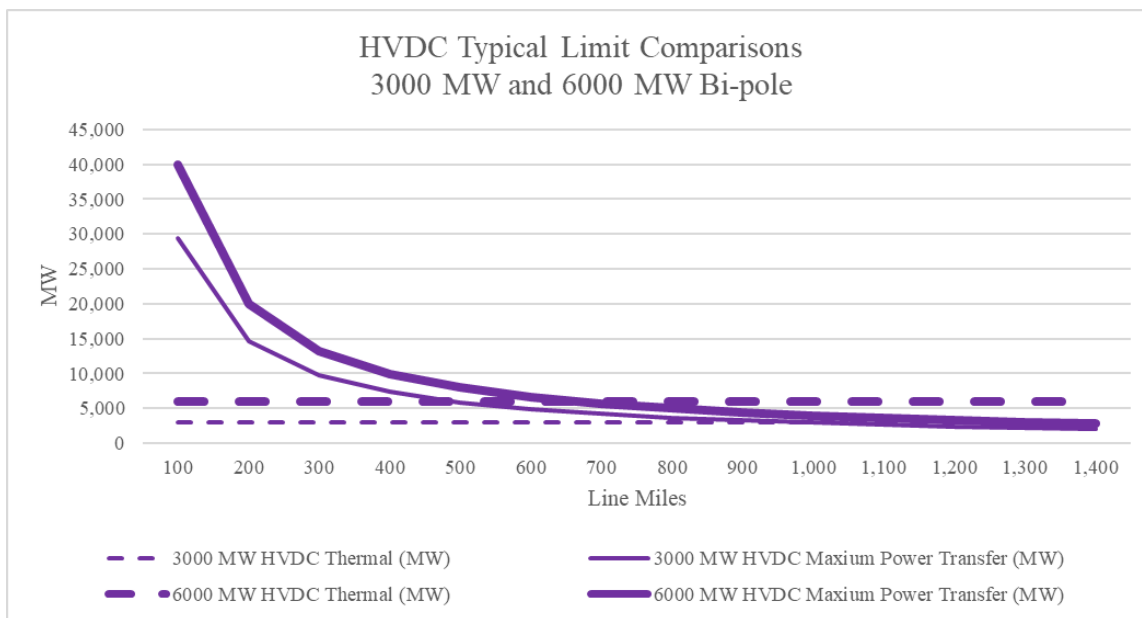

Figure 133. HVDC Typical Limit Comparisons by Line Length

## SAFE LOADING LIMITS

Only AC lines have safe loading limits. A safe loading limit is a risk-based limit and typically represents an inflection point between an operating point of lower reliability risk vs. an operating point of higher reliability risk, hence the name safe loading limit. HVDC lines do not need a safe loading limit because their power flow is precisely controlled which means they can be operated all the way to the maximum power transfer limit without risk of exceeding the maximum power transfer limit or the permissible voltage drop on the HVDC line because of major system disturbances or even minor system perturbations. On the other hand, there should always be a safety margin between the actual operating level and the maximum power transfer limit of an AC line to ensure a major contingency or other sudden change to the operating state of the system does not create an angular or voltage stability issue. Safe loading limits provide such a margin, and like maximum power transfer limits, are inversely related to the line length.

The most common safe loading limit is based on the modified St. Clair curve described in a paper written by three AEP engineers in 1979.<sup>23</sup> In this paper, the safe load limit is designed to limit loading on an EHV AC line to that level which ensures the voltage drop between the sending-end and receiving-end terminals of the line is 5% or less and that loading on the line does not exceed 70% of the steady-state stability limit of the line (often referred to as a 30% stability margin), where the steady-state stability limit for an AC line is equal to the maximum power transfer limit of the AC line. For line lengths of about 200 miles or less, the voltage drop criteria is usually the driving criteria. For line lengths above 200 miles, the steady state stability margin is typically the driving criteria.

<sup>23</sup> Dunlop, R.D., Gutman, R., Marchenko, P.P., *Analytical Development of Loadability Characteristics for EHV and UHV Transmission Lines*, IEEE Transactions on Power Apparatus and Systems, Vol. PAS-98, No. 2, March/April 1979.



The safe loading limit is calculated as follows:

$$\text{Safe Loading Limit (MW)} = \text{SIL} * \text{SCM}$$

Where SIL = Surge Impedance Loading of the Line (MW)

and SCM = St. Clair Multiplier

The Surge Impedance Loading (SIL) of an AC transmission line is the MW loading level where the reactive power produced by the distributed capacitance of the transmission line exactly balances the reactive power consumed by the distributed inductance of the transmission line, thus the transmission line neither produces nor consumes net reactive power. At loading levels below the SIL, the transmission line produces net reactive power. At loading levels above the SIL, the transmission line consumes net reactive power. The surge impedance loading of a transmission line is a function of the line voltage and per mile distributed capacitance and inductance of the line, but not on the line length.

The St. Clair Multiplier is obtained from the St. Clair curve<sup>23</sup> (Figure 14) and is a function solely of line length. The St. Clair Multiplier is a ratio of the Safe Loading Limit of the line to the Surge Impedance Loading of the line at a specified line length. The Safe Loading limit is the MW loading level that either creates a voltage drop across the line of 5% or greater or encroaches into the 30% steady state stability margin. Figure 15 illustrates the Safe Loading limit vs line length for several AC EHV lines.

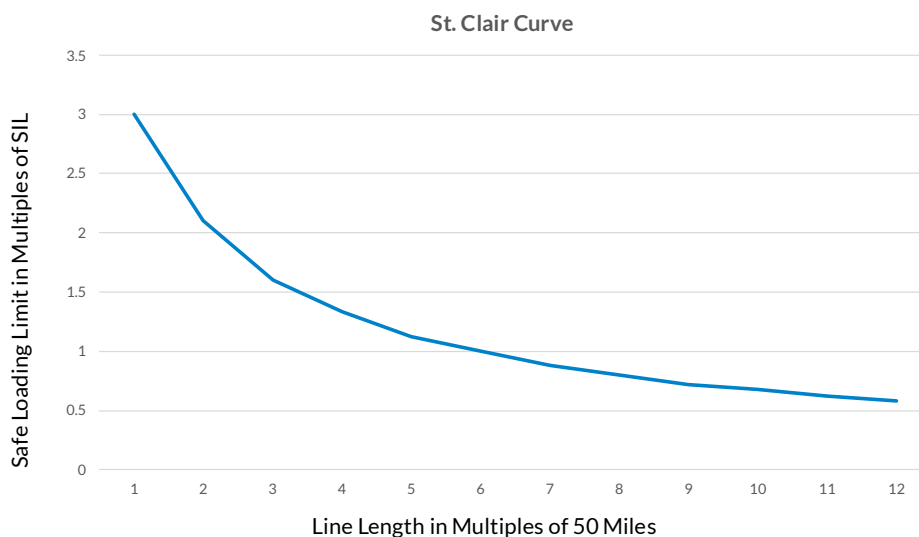
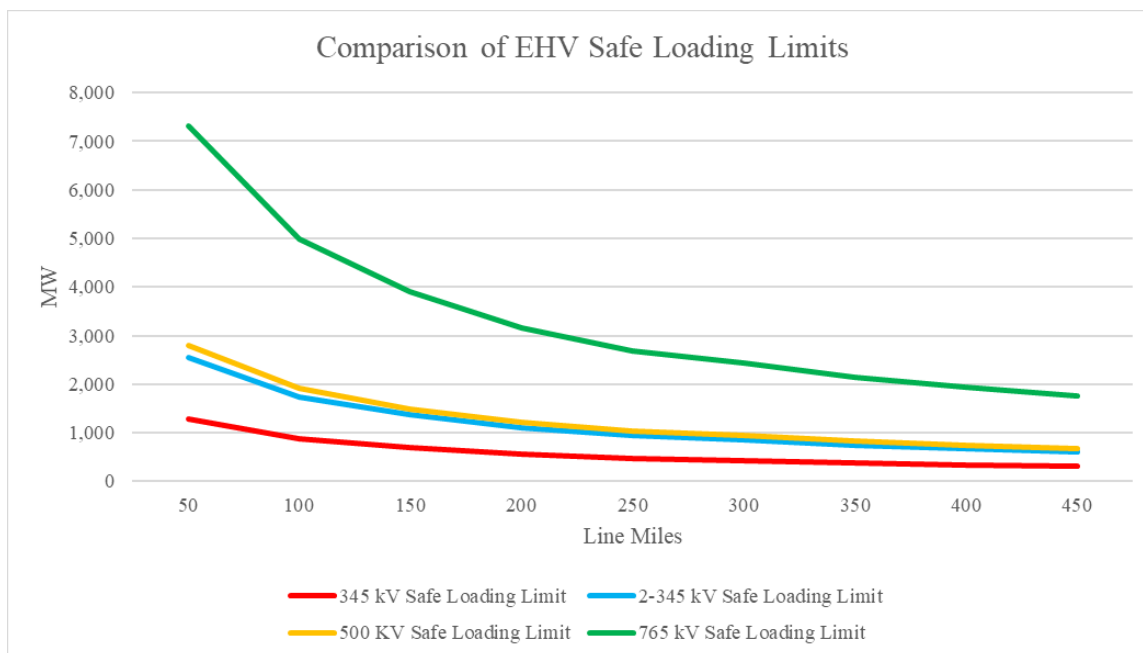

Figure 14: St. Clair Curve, illustrating Safe Loading Limit in Multiples of Surge Impedance Loading for AC EHV lines



**Figure 15: Safe Loading Limit for Various AC EHV Lines**

*NOTE: The graphs above assume that the line terminals are strong (50 kA fault duty)*

### **CROSSOVER POINTS BETWEEN THERMAL LIMIT AND MAXIMUM POWER TRANSFER LIMIT**

The graph shown in Figure 13 (HVDC Typical Limit Comparisons by Line Length) illustrates the crossover points where the maximum power transfer limits of the 3000 MW and 6000 MW +/- 640 kV HVDC bi-pole lines fall below their respective thermal ratings. For the 3000 MW HVDC bi-pole line, the crossover point is at 980 Miles. For the 6000 MW HVDC bi-pole line, the crossover point is at 665 miles. Therefore, for line lengths below 650 miles or so, there is typically no reduction of HVDC line capacity with increasing line length. On the other hand, based on the graph above for AC lines (Comparison of EHV Safe Loading Limits), for 765 kV lines, while conductor thermal limits are high at 6,625 MW, the crossover point where the safe loading limit falls below the thermal limit is at a line length of approximately 60 miles, or about 90 miles if 4000 A terminal equipment is used and the 765 kV thermal ratings falls to 5300 MW (which is applicable to most of the 765 kV lines approved in LRTP Tranche 2.1). These crossover points do not represent maximum limitations on line length nor do they represent break-even distances when considering 765 kV versus HVDC but instead represent the line length where the capacity of the 765 kV line begins to reduce as line length increases. For a 345 kV line, the crossover point where the safe loading limit begins to decrease below the thermal limit is less than 50 miles.

### **COST-PER-MILE IMPACTS OF LINE LENGTHS FOR AC EHV VS. HVDC LINES**

Transmission line capital costs can be broken down into the cost of equipment at the substation terminals and the cost of the line itself. Both EHV AC lines and HVDC lines have certain substation terminal costs. All lines have the cost of AC circuit breakers, breaker disconnect switches, surge arresters, bus conductors, insulators, and similar terminal equipment within the substation footprint. Some EHV AC lines such as 765 kV lines will have shunt reactors connected to the line terminals on the line-side of the



circuit breakers within the substation footprint, thus such equipment is considered part of the terminal equipment costs for the 765 kV line in question. HVDC lines require converters at each terminal, which tend to be very expensive. The costs of all terminal equipment associated with a specific transmission line at the terminating substations can be encapsulated into the term: “zero-mileage” cost. Zero-mileage costs implies that such costs are incurred regardless of the line length and thus are not a function of line length. The “Mileage” costs would then represent the actual cost of the line itself and is a function of line length. The total cost of the line is then the sum of the “zero-mileage” cost and the “mileage” cost. For a typical type of AC or HVDC line, the costs are often expressed in terms of the “zero mileage” cost and the “per mile mileage” costs, and the total cost is then equal to the sum of the zero mileage costs and the product of the per mile cost and the line length in miles.

The costs shown in the table below were estimated in 2023 and represent the zero-mileage and per mile costs of a 765 kV transmission line, 3000 MW +/- 640 HVDC bi-pole line and 6000 MW, +/- 640 kV bi-pole line. The zero-mileage costs of the 765 kV line terminals include two 5000 A circuit breaker positions (one per terminal) and two 300 MVAR shunt reactor banks with dedicated circuit breaker and spare single-phase reactor (one per terminal). The zero-mileage costs of the 3000 MW, +/- 640 kV HVDC bi-pole line includes two 3000 MW, +/- 640 kV VSC HVDC converters (one per terminal) and four 765 kV 3000 A circuit breaker positions (one per pole per converter). The zero-mileage costs of the 6000 MW, +/- 640 kV HVDC bi-pole line includes four 3000 MW, +/- 640 kV VSC HVDC converters (two per terminal) and eight 765 kV, 3000 A circuit breaker positions (one per pole per converter).

The cost per mile of the +/- 640 kV, 3000 MW HVDC line are about half the cost per mile of the 765 kV line option or the +/- 640 kV, 6000 MW option. The cost per mile of the 765 kV line option and the +/- 640 kV, 6000 MW option are about the same. The 765 kV Line has three conductors compared to two conductors for the 6000 MW HVDC line (both lines use 6-795 Aluminum Conductor Steel Reinforced (ACSR) conductor bundles), but the HVDC line requires some additional vertical and horizontal clearances for the conductors, so the per-mile costs of these two options is roughly the same.

LINE TYPE	ZERO-MILEAGE COST (TERMINAL COSTS) MILLION \$	LINE COST PER MILE MILLION \$ / MILE
765 KV AC OVERHEAD LINE (6-795 ACSR CONDUCTOR BUNDLE)	\$ 62.6	\$5.0
+/- 640 KV, 3000 MW HVDC BI-POLE (2-1590 ACSR CONDUCTOR BUNDLE)	\$1,658.0	\$2.7
+/- 640 KV, 6000 MW HVDC BI-POLE (6-795 ACSR CONDUCTOR BUNDLE)	\$3,316.0	\$5.0

Table 2: Comparison of zero-mileage cost and line costs between AC 765KV and HVDC lines

Based on the information in Table 3, the zero-mileage costs of the HVDC options are significantly greater than the zero-mileage costs of the 765 kV options, whereas the per mile costs of the HVDC options are less than or the same as the per mile costs of the 765 kV options.



## LINE LENGTH IS THE KEY CONSIDERATION DRIVING THE CHOICE BETWEEN EHV AC VS. HVDC

For line lengths below 650 miles, the capacity of EHV AC lines tends to diminish with line length when the safe loading limit of the EHV AC lines falls below the thermal limit of the EHV AC line, whereas the capacity of the HVDC lines tends to remain constant with line length at the thermal rating. This is illustrated by Figure 16 below.

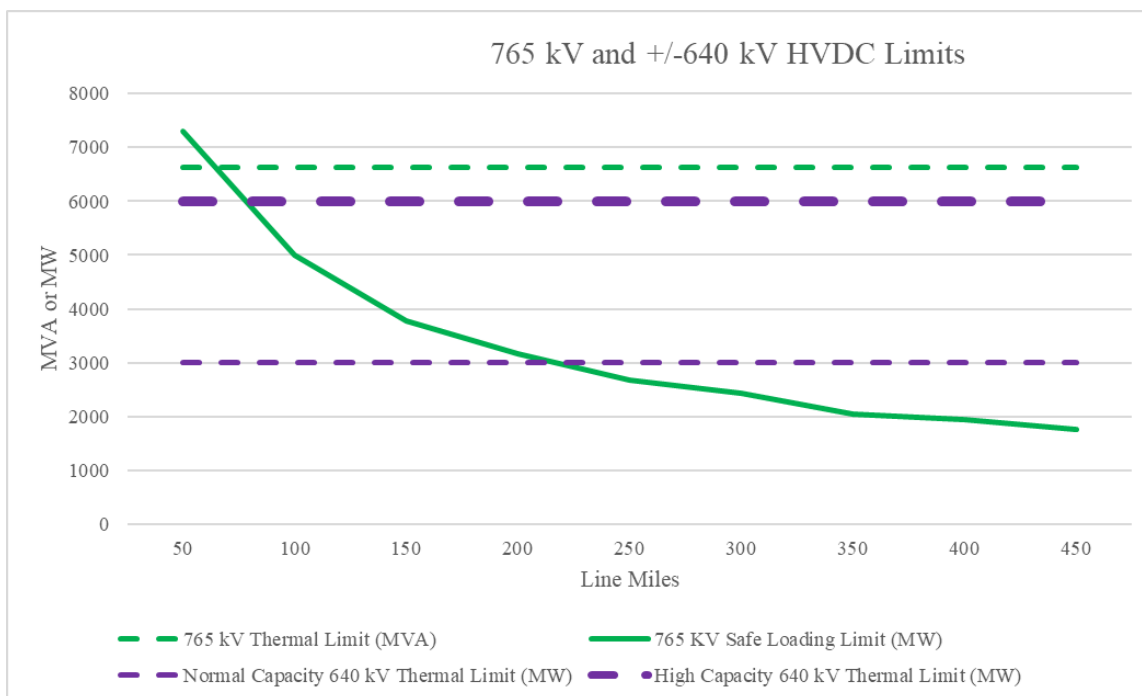

Figure 16: Comparison of 765 kV and HVDC line capacity and safe loading limits vs line length

Furthermore, HVDC lines have very high “zero-mileage” costs whereas the zero-mileage cost of an EHV AC lines are much lower. The per-mile cost of an HVDC line tends to be the same or lower than the per-mile cost of an EHV AC line of comparable voltage level. In summary, HVDC lines have very high zero-mileage costs, but the capacity of an HVDC line does not diminish with line length. Furthermore, the per-mile costs of HVDC lines tend to be less than or equal to the per-mile costs of EHV AC lines. Having said this, when EHV AC lines are compared with HVDC lines on a cost per MW-mile basis, the EHV AC lines are more economical below a certain line length and the HVDC lines are more economical above a certain line length. Figure 17 was prepared in 2023 based on the 2023 cost estimates in Table 3 and the 765 kV and +/- 640 kV HVDC line limits in Figure 16. It is important to note that the actual breakeven mileage can vary significantly based on changing assumptions, such as voltage level, type of conductor used, type of converter used, and other such design criteria, so in general, a single breakeven point should be avoided, and a breakeven range should be considered instead. The breakeven range in Figure 17 is 250 to 400 miles. Above 400 miles, HVDC tends to be more economical whereas below 250 miles 765 kV tends to be more economical. For line lengths above 250 miles and below 400 miles, the choice of 765 kV vs. HVDC should be analyzed in more detail.

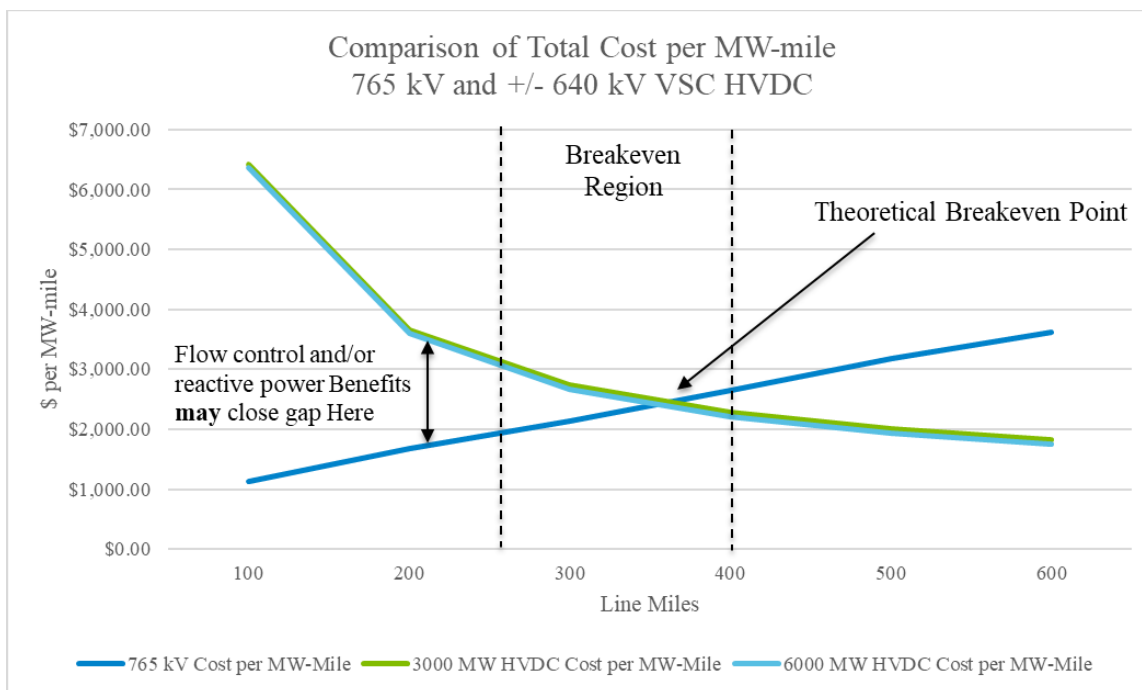

Figure 17: Comparison of Total Cost per MW-mile: 765 kV and +/- 640 kV VSC HVDC

## THE BENEFITS OF HVDC FLOW CONTROL VERSUS THE BENEFITS OF AC NATURAL FLOW RESPONSE

There are potential flow control benefits provided by HVDC lines under certain scenarios and conditions and potential natural flow response benefits associated with EHV AC lines under other scenarios and conditions. It is important to discuss the pros and cons of flow control versus natural flow response and how this consideration could impact the choice between an EHV AC line and an HVDC line.

Regarding AC lines, it is well known that the flows on AC lines are a natural function of the following:

- The topology of the AC transmission system and the characteristics of AC transmission facilities (e.g., line impedances and shunt susceptance, etc.).
- The location and magnitude of generation, load, and other shunts (e.g., capacitor banks, etc.).
- The status of generation and transmission facilities (forced outages, planned outages, unit commitment, switched shunts, tap changers, etc.)

It is important to note that there are devices that can be used on the AC transmission system to influence transmission flows, but these techniques simply alter the topology and/or characteristics of the AC system and do not precisely control the flows on AC transmission facilities. The more common methods of controlling flows on the AC system are:

- Switchable series reactors or capacitors (very limited control options – in or out).
- Phase angle regulator transformers (rough control at best – not continuous).



- Static synchronous series compensators (more precise control, but not as precise as HVDC flow control – often incorporated into “smart wire” technology).

Unlike flows on AC transmission facilities, the flows on HVDC lines are precisely scheduled or controlled. Common methods of scheduling or controlling flows on HVDC lines include the following:

- Manually entered schedules.
- Automatic controls to follow the output of a source generation resource.
- Automatic controls to emulate an AC transmission line natural response (based on voltage phase angles at the AC terminals of the HVDC line and a simulated proxy impedance).
- Potentially dispatching HVDC flows in real-time via Security Constrained Economic Dispatch to co-optimize resource outputs with HVDC schedules.

A primary distinction between the flows on AC transmission lines versus HVDC transmission lines is that AC transmission line flows are natural and HVDC transmission flows are precisely scheduled. The response of AC transmission flows to changes in generation output, load, and system topology is natural and nearly instantaneous. Natural and nearly instantaneous transmission flow response can be a good thing or a bad thing. The response of HVDC transmission flows to changes in generation output, load, and system topology requires manual intervention or control action, and while it can be fast, it is not instantaneous. The requirement of flows on HVDC transmission lines to be controlled or scheduled can be a good thing or a bad thing.

The ability to control flows on HVDC lines can provide several benefits. Because HVDC flows are scheduled and not dependent on the transmission system topology and characteristics, the entire capacity of an HVDC line can be used whenever needed and there is no risk that a major system disturbance or minor system perturbation will cause the HVDC line to overload or exceed its maximum power transfer limit. This allows an HVDC line to act like a “vacuum cleaner”, absorbing flow off heavily loaded parallel AC lines up to the capacity of the HVDC line without a risk that the HVDC bi-pole could become overloaded following a major contingency or minor system change. This requires of course that the underlying AC system be strong enough to withstand a monopole or bi-pole trip of the HVDC facility.

Another potential benefit of the ability to control flows on HVDC lines is to co-optimize the HVDC schedules with resource outputs to further minimize AC transmission congestion and overall transmission system losses, which of course will further minimize overall production costs. The co-optimization of HVDC schedules with resource outputs can be accomplished via modifications to the day-ahead market security constrained unit commitment and security constrained economic dispatch algorithms, the security constrained unit commitment algorithms used in the various reliability assessment commitment processes, and the security constrained economic dispatch algorithm used to clear the real-time market. MISO is presently pursuing the capability to dispatch and co-optimize HVDC lines. More information is provided in the markets section of this white paper on MISO work to date and future MISO plans.

While the ability to control flows on the HVDC lines can provide several benefits, the lack of natural flow response on the HVDC lines can be problematic under a future where generation dispatch and load is much more volatile. For example, fast morning ramp-down of wind in one region coupled with fast



morning ramp-up of solar in another region (or vice versa) can cause very fast and significant changes to flow patterns on the AC system. Fast or near instantaneous ramping of large data centers can be equally problematic. If HVDC schedules do not quickly follow these fast and significant changes in resource dispatch and load, the result can be substantial congestion and/or reliability risk on the underlying AC transmission system. In the past, there are situations where the flow on a 765 kV line changed from 3000 MW in one direction to 3000 MW in the opposite direction within a 12-hour period. These changes were not driven by major outages of generation or transmission facilities but instead changes in generation dispatch and load. In the future, as the penetration of renewable generation continues to increase, resource dispatch becomes more volatile, large data center loads become a much higher percentage of the total system load, and the overall volatility of load becomes much greater, the magnitude and speed of AC line flow changes could increase significantly. These volatile flow changes are not an issue with AC transmission since the flow response of AC transmission is natural and adjusts as generation output and load levels adjust, thus volatile changes in generation dispatch and load (i.e., major ramping) is followed perfectly by AC lines. For HVDC, it is necessary to stay on top of significant and fast changes in generation and load to ensure HVDC schedules follow these generation and load changes, otherwise the flow control requirement of HVDC lines could compound the issues.

Regarding flow control, VSC HVDC equipment is capable of very fast response and bi-directional response, so there are two strategies to mitigate (but not totally eliminate) the lack of natural response by VSC-based HVDC lines. First, it is possible to mitigate the requirement for flow control and the lack of natural flow response on HVDC lines by installing a control system that simulates the natural response of an AC line. Such a control system would simulate a predetermined proxy AC line impedance and then continuously control flows on the HVDC line based on the phase angle difference between the bus voltages at the sending and receiving AC terminals of the HVDC line. For long distance lines where the capacity of an AC line is significantly derated based on the length of the line, this is a promising strategy. For shorter and intermediate distances where the capacity of the AC line is not significantly derated, it would likely be best to simply install an AC line instead and save the cost of the HVDC converter equipment that would otherwise be required.

A more promising mitigation strategy being pursued by MISO is to allow the real-time market security constrained economic dispatch algorithm that clears the real-time market to also co-optimize HVDC schedules with resource outputs every five (5) minutes. This does not provide instantaneous natural response, but does allow for automatic control of HVDC schedules to occur every five (5) minutes based on data that is ten (10) to fifteen (15) minutes old (i.e., the real-time dispatch is updated every five (5) minutes and initiated about ten (10) minutes ahead of the targeted dispatch time point in the real-time market using inputs that are up to five (5) minutes old). In addition to mitigating congestion and minimizing losses in general, dispatchable HVDC can also mitigate (but not totally eliminate) the lack of natural response on HVDC lines during times when generation dispatch and load is volatile. As stated before, more information is available elsewhere in this whitepaper on the concept of dispatchable HVDC and the work that is currently underway to research and develop dispatchable HVDC at MISO.

In summary, the flow control capabilities of HVDC lines can provide substantial benefits, but the lack of natural flow response in HVDC lines can also cause substantial issues. While flow control can be a benefit



for HVDC, it can also cause issues, thus the assessment of net flow control benefits on any HVDC line must be studied on a case-by-case basis.

## **CONSIDERATION OF ANCILLARY BENEFITS IN PLANNING INTRA-REGIONAL HVDC LINES**

The HVDC industry has been articulating several ancillary benefits provided by VSC HVDC technology and has claimed that these ancillary benefits must always be considered in making planning decisions regarding the pursuit of VSC HVDC transmission solutions versus EHV AC transmission solutions. In some cases, many of these ancillary benefits are valid. In some cases, these ancillary benefits are only realized in certain situations. Lastly, some of the touted ancillary benefits are either not valid or at best are dependent on several variables and thus must be considered on a case-by-case basis. Listed below are the most common ancillary benefits and a brief discussion on situations where there may be valid benefits that deserve due consideration:

### **Dynamic Reactive Power and Voltage Control**

While LCC HVDC technology consumes substantial amounts of reactive power and does not allow for voltage control, VSC HVDC technology does not need to consume reactive power and can inject or absorb reactive power independently of real or active power schedules at each AC terminal. The VSC converter is thus a source of dynamic reactive power and voltage control and basically acts as a STATCOM at each AC terminal of the HVDC line. This is a valid benefit and could be substantial for contributing to dynamic voltage recovery.

The assessment of the dynamic reactive power benefits must consider other potential sources for dynamic reactive power and whether those sources would be in place regardless. One potential resource is synchronous machines. To the extent there are conventional resources with synchronous generators in the vicinity of the AC terminals of an HVDC line, such resources may be able to provide the dynamic reactive power needs of the system as well in this area, thus the dynamic reactive power benefits provided by the HVDC VSC converters, while valid, are also unneeded since there is no deficit in dynamic reactive power supply in the area. These conventional generation resources could represent older legacy generating units or newly installed generation resources such as combined cycle gas generation resources or small modular reactor resources that continue to use synchronous machines. It is important to note that synchronous machines are not always on-line, and to the extent a resource that drives a synchronous generator is off for economy or other reasons, such resource will not be able to supply dynamic reactive power except for rare situations where the unit is set up to operate as a synchronous condenser when the prime mover is off-line.

It is also important to note that both the grid following and grid forming inverters that enable the interconnection of renewable energy resources such as wind and solar, as well as energy storage resources such as electric batteries, are also generally capable of providing dynamic reactive power and voltage control. With respect to grid following inverters, which are the most common inverters in place today for wind and solar resource, these inverters act as current sources and can control the phase angles of the currents they inject into the system with respect to the phase angles of the AC voltages at their terminals to dynamically inject or absorb reactive power within the limits of the inverter. MISO requires IBRs to provide dynamic reactive current injection during voltage ride-through events. Grid forming inverters act as voltage sources capable of generating the inverter's internal output voltage magnitude,



phase angles, and frequency. These types of inverters behave similarly to synchronous machines, except for typically having a lower fault current rating. Grid Forming Inverters are essentially equivalent to STATCOMs, but unlike STATCOMs, are not in place to provide dynamic reactive power, but instead are in place to facilitate the interconnection of renewable energy resources and battery energy storage systems. In any event, to the extent dynamic reactive power and voltage control is available from grid following and/or grid forming inverters across the system installed for the purpose of interconnecting generation resources, the dynamic reactive power capabilities of these inverters are ancillary benefits that can be used to meet dynamic reactive power benefits, thus diminishing or eliminating the actual dynamic reactive power ancillary benefits from VSC HVDC converters in the area in most cases.

Three additional points need to be made regarding the use of grid following and grid forming inverters as sources of dynamic reactive power. First, some in the industry have expressed concern that the dynamic reactive power capabilities of inverters are less than the dynamic reactive power capabilities of traditional synchronous machines, and the displacement of synchronous machine based resources with inverters could create a deficit in dynamic reactive power needs that could be met or partially met by the VSC converters associated with HVDC lines, thus the dynamic reactive power ancillary benefits of VSC HVDC lines should always be considered. The reactive power capabilities of synchronous machines and inverters are based on the specific capability curves of the machine or device and vary with the real power output of the resource. However, the rated power factors of the machine can be used to estimate relative reactive power capabilities of a synchronous machine versus an inverter. For example, a typical rated power factor for a synchronous machine might be 85%, which means the reactive power injection capabilities of a 100 MW synchronous machine resource operating at full output would be approximately 62 MVAR. A typical rated power factor for an inverter might be 95%, which means the reactive power injection capabilities of a 100 MW inverter-based resource operating at full output would be approximately 33 MVAR or nearly half the reactive capability of a synchronous machine resource of the same size. Based on this, one might believe that inverters will not be capable of providing the same level of reactive power as the synchronous machines they are displacing. However, it is important to note that the aggregate nameplate capability of installed inverters will be much greater than the nameplate capacity of the synchronous generators they are displacing. The reason for this is that the capacity credit for conventional resources driving synchronous machines is much higher than the capacity credit of the inverter-based resources, thus the aggregate nameplate capacity of installed renewable resources and associated inverters will be much higher than the aggregate nameplate capacity of the synchronous machine based resources being displaced. This means that the lower reactive power capabilities of inverters on a “per MVA” capacity basis will be applied to a much higher MVA capacity base, thus there may not be a deficit of resource-based dynamic reactive power capability in the future. The other important point to remember is that inverters, like VSC HVDC converters, allow for the independent control of real and reactive power, and thus can be on-line providing dynamic reactive power at all times, even when there is zero real or active power being injected by the associated renewable resource or injected or withdrawn by the associated battery energy storage system. This provides an advantage that even the conventional synchronous machine fleet did not provide, and that is 24/7 dynamic reactive power capability even when the resources prime energy source is unavailable. This eliminates any dynamic reactive power concerns that might be associated with inverter-based resources that have low availability because they are associated with low-capacity factor resources. Finally, it is important to note



that when renewable resources with many inverters are the source of dynamic reactive power in an area, such resources will be distributed across the area. The assignment of dynamic reactive power responsibilities to a greater number of smaller sized inverters that are distributed across an area versus to a fewer number of larger sized HVDC VSC inverters that are not as distributed has benefits as well in terms of distributing voltage support and avoiding larger dynamic power generation contingencies.

In summary, while VSC HVDC converters can provide a substantial amount of dynamic reactive power capability, this capability is likely to be available by future resources whether they be synchronous machine resources or inverter-based resources, thus the actual net benefit of the VSC HVDC converter capabilities to provide dynamic reactive power is negated in many cases.

### **GRID FORMING CAPABILITIES**

Unlike LCC HVDC converters, which are similar to grid following inverters, VSC HVDC converters can generate AC grid voltage waveforms, and this is a potential benefit to the system. Before electric power can be generated or transported, there must be AC voltages present in the system since AC voltages are necessary prerequisites for the generation and delivery of electrical energy. Historically capabilities such as inertia and voltage waveform formation have been taken for granted since these capabilities are inherent capabilities of a synchronous machine. However, the most common inverter on the system today is the grid following inverters, and such inverters have no grid forming capabilities. This is not an issue when the percentage of the resource fleet made up of grid following inverters is small, but as more of the resource capacity uses grid following inverters, issues may be introduced regarding system stability, lack of voltage control and lack of black start capability.

As discussed earlier, an assessment of the benefit to the grid-forming capabilities of VSC HVDC converters must also consider if these benefits are available from other sources. Both synchronous machines and grid forming inverters can form voltage waveforms, and to the extent sufficient quantities of such resources exist in the vicinity of the AC terminals of a VSC HVDC line in the future, the overall grid forming benefits of VSC HVDC converters could be significantly diminished. This is based on the same argument made for dynamic reactive power. To the extent synchronous machine generation resources make up a portion of the future generation fleet (e.g., combined cycle gas resources, small modular reactors, etc.), some of the retiring synchronous machines could be replaced with new synchronous machines. Furthermore, if a shift begins to occur toward grid forming inverters and away from grid following resources for inverter-based resource interconnections, the potential grid forming benefits of VSC HVDC converters could be significantly diminished since such capabilities are already provided for by grid forming inverters and not needed by VSC HVDC converters.

It is important to note that there is a small but very specific benefit provided by VSC HVDC lines tied to grid forming capabilities that is not available for LCC HVDC lines. A VSC HVDC line installed between two asynchronous areas will facilitate black starting one asynchronous area from the other area. While there are likely other local alternatives for black starting a dead area using local grid forming resources, an LCC HVDC line between the two asynchronous areas would not have the capability to black start one area from the other since LCC HVDC lines require voltage to be present at each AC terminal, but unlike VSC HVDC converters, cannot generate those voltage waveforms.



## **Voltage and Angular Stability Benefits**

The key steady state voltage and angular stability benefits in steady state are discussed above, with line length as a key consideration in determining if a new line should be an EHV AC line or HVDC line. With respect to an EHV AC line, the longer the line, the larger the steady state voltage drop, the lower the maximum power transfer limit and the lower the safe loading limit. For longer EHV AC lines, there is always greater risk of low voltage issues, voltage stability issues, and/or angular stability issues. Line length is not so much an ancillary benefit as it is a key consideration to the choice between EHV AC versus HVDC, as was discussed above in detail.

It is important to note that there is a specific ancillary benefit of VSC HVDC lines related to supporting angular stability via special control actions known as fast power modulation. Through rapid power flow control, VSC HVDC lines can rapidly increase or decrease power transfer, responding within milliseconds to changes in system conditions. This type of control can be used to dampen inter-area oscillations caused by large-scale swings in power flow between regions, which helps stabilize the system during and after faults. The VSC HVDC line with fast power modulation acts as a shock absorber in the event of disturbances (e.g., sudden loss of generation or load). The HVDC link can temporarily absorb or inject power, stabilizing frequency and angular separation between generators, thus preventing loss of synchronism which could potentially result in a wide area blackout.

## **Flow Control Benefits**

One of the major ancillary benefits associated with HVDC lines is the flow control capabilities of HVDC in general and VSC HVDC in particular. MISO sees this more as a key consideration, which in addition to line length, is the primary driver for choosing either an HVDC solution or an EHV AC solution for a specific set of issues. As such, flow control was discussed earlier in the whitepaper as were the potential tradeoffs between the benefits of having the flow control capabilities of an HVDC line versus the issues associated with the lack of natural flow response capability by HVDC lines as discussed above.

## **Transfer Loss Reduction**

Another ancillary benefit claimed for HVDC lines is lower transfer losses associated with HVDC lines in general. However, MISO has found this is not necessarily the case. It is true that higher voltage levels tend to result in much lower load losses in general, but that conclusion is not driven by whether the line is an HVDC line or EHV AC line. There are certain factors that help reduce losses in HVDC lines compared to AC lines, most notably the fact that DC line resistances are lower than AC lines resistances for the same conductor due to skin effect and the fact that for a given voltage level, the corona losses associated with an HVDC line may be lower than the corona losses associated with a comparable AC line. It has been said that an HVDC line contains only two conductors compared to three conductors for an AC line, thus the losses on the AC line for the same size conductors (neglecting the difference between the AC and DC resistance) would be 150% of the losses of the HVDC line, everything else equal (losses associated with three conductors versus two conductors). What this simple analysis fails to consider is the converter losses. Converter losses for VSC HVDC lines are often estimated at 0.7% per terminal or 1.4% for the total zero-mileage load losses. There are no zero-mileage load losses associated with AC lines, and when these losses are factored into the total transfer losses of an HVDC line, particularly for lines with lengths of 300 miles or less, there is no evidence to suggest that HVDC lines have lower losses than comparable



EHV AC lines when converter losses are considered. For extremely long lines (above 400 miles) where the converter losses become a smaller percentage of total losses, the total HVDC losses could be less, but other factors would tend to favor HVDC for these longer lines as discussed above. Table 4 below compares the loss levels for various VSC HVDC and EHV AC choices to further illustrate these points.

Type	kV	Length	MW Flow	Current (A)	R ( $\Omega$ per Mile)	Line Losses (MW)	Converter Losses (MW)	Line Losses (%)	Converter Losses (%)	Total Losses (%)
HVDC Bi-pole	600	225	3000	2500	0.019008	53.5	42.0	1.78%	1.40%	3.182%
EHV AC Single circuit	765	225	3000	2264	0.023144	80.1	0.0	2.67%	0.00%	2.669%
HVDC Bi-pole	500	325	2000	2000	0.028512	74.1	28.0	3.71%	1.40%	5.107%
EHV AC Single circuit	765	325	2000	1509	0.023144	51.4	0.0	2.57%	0.00%	2.571%
HVDC Bi-pole	500	100	2000	2000	0.028512	22.8	28.0	1.14%	1.40%	2.540%
EHV AC Single circuit	765	100	2000	1509	0.023144	15.8	0.0	0.79%	0.00%	0.791%
EHV AC Single circuit	500	100	2000	2309	0.040128	64.2	0.0	3.21%	0.00%	3.210%
EHV AC Double-circuit	345	100	2000	3347	0.018348	61.7	0.0	3.08%	0.00%	3.083%

**Table 3: Comparison of Line Losses across VSC HVDC and EHV AC Transmission Options**



## 7 Future Work

This section summarizes the recommendations from the impact assessment, organized by priority. The recommendations are not time-bound but do have three levels of priority, as is explained below.

Recommendations beginning with:

- **“MISO should”** are high priority relative to other HVDC recommendations. These actions relate to a reliability concern or stakeholder priority.
- **“As HVDC penetration increases, MISO should”** are medium priority relative to other HVDC recommendations, with the need linked to additional deployment of HVDC facilities in MISO. These actions can wait until planned HVDC facilities proceed further in their development.
- **“MISO could”** are lower priority. These are issues and ideas that have arisen in MISO’s assessment that might have value but are not necessarily pressing.

	Workstream	Recommendation Title	Recommendation
High	Merchant HVDC	<b>Improvements to MISO Attachment GGG process</b>	MISO is making Tariff language changes to Attachment GGG, updating the MISO MHVDC interconnection process, and making Limited Operation clarifications for interim periods on qualified MHVDC projects and will continue to engage with stakeholders on these issues through the IPWG and PAC.
	Merchant HVDC	<b>MHVDC Business Practice Manual</b>	MISO is creating an MHVDC BPM focusing on MHVDC application, application modification, application withdrawal, study scope, process timelines, study requirements, affected system studies, and Pre-TCA considerations.
	Reliability Operations	<b>Contingency management procedures for HVDC facilities</b>	MISO should continue to update the MSSC and contingency reserve requirements as system conditions evolve to ensure reliability.
	Resource Adequacy	<b>Resource Adequacy treatment of External Resources, including those delivered via HVDC</b>	MISO should collaborate with stakeholders to clarify how External Resources, including those delivered by HVDC-enabled firm transmission, are modeled and participate under MISO’s current Resource Adequacy construct.
	Resource Adequacy	<b>Accreditation enhancements for External Resources</b>	MISO should evaluate updating the accreditation of external resources to improve alignment with the Direct Loss of Load Resource Adequacy (RA) Hours approach.
Medium	Markets	<b>Interchange and market-to-market congestion management processes</b>	As penetration of HVDC increases, MISO should evaluate approaches to integrate HVDC into interchange and market-to-market congestion management processes and discuss these approaches with our neighbors.
	Markets	<b>Intra-regional HVDC in market and operations processes</b>	As HVDC penetration increases, MISO should evaluate these potential approaches to partially integrate intra-regional HVDC into market and operations practices.
	Reliability Operations	<b>Contingency management procedures for HVDC facilities</b>	As HVDC penetration increases, MISO should assess the risk of contingency reserve cost increases and evaluate opportunities to mitigate these increases through reserve sharing agreements or alternative cost allocation processes.
	Reliability Operations	<b>HVDC impacts on system stability risk</b>	As penetration of HVDC facilities increases, MISO should conduct, or coordinate with other entities to conduct frequency, voltage, and rotor angle stability risk assessments related to the loss of the HVDC facility, as well as assess converter-driven stability risks.
	Reliability Operations	<b>Outage coordination and operator visibility for HVDC facilities</b>	As penetration of HVDC facilities increases, MISO should evaluate more granular representation of de-rates during outage coordination processes and enhanced representation of HVDC facilities in the energy management system and consider other enhancements to improve operator visibility.
	Expansion Planning	<b>Test modeling and performance of PROMOD HVDC simulation capabilities</b>	As a medium priority, MISO should test the modeling and performance of the dispatchable and co-optimized HVDC capability of PROMOD to ensure it is an acceptable proxy for the dispatchable HVDC solution to be developed by the market side.



	Workstream	Recommendation Title	Recommendation
Low	Markets	<b>Intra-regional HVDC in market and operations processes</b>	MISO could continue to research open questions related to full integration.
	Markets	<b>HVDC in congestion hedging processes</b>	MISO could assess the risk of FTR underfunding and possibility of missed hedging opportunities and evaluate potential process enhancements to better align FTR auctions with evolving operational practice.
	Resource Adequacy	<b>Representation of transmission in Resource Adequacy risk modeling</b>	MISO could evaluate methods for incorporating transmission lines, including HVDC, into Resource Adequacy risk modeling.
	Expansion Planning	<b>Investigate feasibility of AC line emulation controls</b>	MISO could further investigate the feasibility of AC line emulation controls as an option for future regional HVDC lines where AC response is desired, but the line length is too long for an AC line.

**Table 5: Summary of recommendations based upon HVDC Impact Assessment, in order of priority with corresponding work stream identified**



# 8 Acronyms and Glossary

## ACRONYMS

<b>AC:</b> Alternating Current	<b>FRAP:</b> Fixed Resource Adequacy Plan	<b>MSC:</b> Market Sub-Committee	<b>RTO:</b> Regional Transmission Operator
<b>ACE:</b> Area Control Error	<b>FTR:</b> Financial Transmission Right(s)	<b>MSSC:</b> Most Severe Single Contingency	<b>SAC:</b> Seasonal Accredited Capacity
<b>ACSR:</b> Aluminum Conductor Steel Reinforced	<b>GADS:</b> Generating Availability Data System	<b>MTEP:</b> MISO Transmission Expansion Plan	<b>SCADA:</b> Supervisory Control and Data Acquisition
<b>AEMO:</b> Australia Energy Market Operator	<b>GFM:</b> Grid Forming (Inverter)	<b>MVAR:</b> Megavolt-Ampere Reactive	<b>SCED:</b> Security Constrained Economic Dispatch
<b>AFC:</b> Available Flowgate Capability	<b>GSF:</b> Generation Shift Factor	<b>MW:</b> MegaWatt	<b>SCM:</b> St. Clair Multiplier
<b>AGC:</b> Automatic Generation Control	<b>GVTC:</b> Generator Verification Test Capacity	<b>NEM:</b> (Australia's) National Electricity Market	<b>SCR:</b> Short Circuit Ratio
<b>ARS:</b> Automated Reserve Sharing	<b>HVDC:</b> High Voltage Direct Current	<b>NERC:</b> North American Reliability Corporation	<b>SCUC:</b> Security Constrained Unit Commitment
<b>BA:</b> Balancing Authority	<b>Hz:</b> Hertz	<b>NERC BAL:</b> Resource and Demand Balancing (BAL) body of standards	<b>SDAC:</b> Single Day-Ahead Coupling
<b>BAA:</b> Balancing Authority Area	<b>IBR:</b> Inverter-Based Resource	<b>NERC TPL:</b> Transmission Planning body of standards	<b>SDX:</b> System Data Exchange
<b>BPA:</b> Bonneville Power Administration	<b>ICCP:</b> Inter-control Center Communication Protocol	<b>NLR:</b> National Laboratory of The Rockies	<b>SE:</b> State Estimator
<b>BPM:</b> Business Practice Manual-(MISO)	<b>IDC:</b> Interchange Distribution Calculator	<b>NSI:</b> Net Scheduled Imports	<b>SERVM:</b> Strategic Energy Risk Valuation Model (Resource Adequacy Software)
<b>CA:</b> Contingency Analysis	<b>IEEE:</b> Institute of Electrical and Electronics Engineers	<b>NYISO:</b> New York Independent System Operator	<b>SIDC:</b> Single Intraday Coupling
<b>CAISO:</b> California Independent System Operator	<b>IESO:</b> Independent Electricity System Operator	<b>OMS:</b> Organization of MISO States	<b>SIL:</b> Surge Impedance Loading of the Line (MW)
<b>CB:</b> Circuit Breaker	<b>IGBT:</b> Insulated Gate Bipolar Transistor	<b>ONS:</b> National Electric System Operator of the Brazilian National Interconnected System (SIN)	<b>SLG:</b> Single Line to Ground
<b>CIL:</b> Capacity Import Limit	<b>IMM:</b> Independent Market Monitor	<b>PAR:</b> Phase Angle Regulator	<b>SPP:</b> Southwest Power Pool
<b>CEP:</b> Capacity Export Limit	<b>INELFE:</b> Electrical Interconnection Spain – France	<b>PDCI:</b> Pacific Direct Current Intertie	<b>SPS:</b> Special Protection Systems
<b>CP:</b> Commercial Pricing (Node)	<b>ISA:</b> Interconnection Service Agreement (NYISO Merchant HVDC)	<b>PJM:</b> Pennsylvania-New Jersey-Maryland Interconnection	<b>SREA:</b> Southern Renewable Energy Association
<b>CPNY:</b> Clean Path New York (Project)	<b>ISBA:</b> Integral Square Bus Angle	<b>PMU:</b> Phasor Measurement Unit	<b>STATCOM:</b> Static Synchronous Compensator
<b>CROW:</b> Control Room Operations Window	<b>ISO:</b> Independent System Operator	<b>POI:</b> Point of Interconnection	<b>SSCTI:</b> Sub-Synchronous Control Torsional Interactions
<b>CRR:</b> Congestion Revenue Rights (CAISO)	<b>ISONE:</b> Independent System Operator New England	<b>PPA:</b> Power Purchase Agreement	<b>TCA:</b> Transmission Control Agreement (CAISO); Transmission Connection Agreement (MISO)
<b>CRSG:</b> Contingency Reserve Sharing Group	<b>JOA:</b> Joint Operating Agreement	<b>PRA:</b> Planning Reserve Auction	<b>TCC:</b> Transmission Congestion Contracting (NYISO)
<b>CTS:</b> Coordinated Transaction Scheduling	<b>kV:</b> Kilovolt	<b>PRM:</b> Planning Reserve Margin	<b>TCR:</b> Transmission Congestion Rights (SPP); Transmission Connection Request (MISO)
<b>DA:</b> Day-Ahead	<b>LCC:</b> Line Commutated Converter	<b>PRMR:</b> Planning Reserve Margin Requirements	<b>TDF:</b> Transfer Distribution Factor
<b>DC:</b> Direct Current	<b>LCR:</b> Local Clearing Requirements	<b>PSCAD:</b> Power Systems Computer-Aided Design (Manitoba Hydro)	<b>TPL:</b> Technology Performance Level



<b>DCR:</b> Direct Current Reactor		<b>PWL:</b> Piecewise Linear	<b>TLR:</b> Transmission Loading Relief
<b>DCCB:</b> Direct Current Circuit Breaker	<b>LMP:</b> Locational Marginal Price	<b>PWM:</b> Pulse Width Modulation	<b>TSAT:</b> Transient Security Assessment Tool
<b>DLOL:</b> Direct Loss of Load	<b>LMR:</b> Load Modifying Resources	<b>RA:</b> Resource Adequacy	<b>TSO:</b> Transmission System Operator
<b>DMR:</b> Dedicated Metallic Return	<b>LOLE:</b> Loss of Load Expectation	<b>RAR:</b> Resource Adequacy Requirements	<b>UFLS:</b> Under Frequency Load Shedding
<b>EHV:</b> Extra High Voltage	<b>LRTP:</b> Long-Range Transmission Plan	<b>RAS:</b> Remedial Action Scheme	<b>VSC:</b> Voltage Source Converter
<b>EI:</b> Eastern Interconnection	<b>LSE:</b> Load Serving Entity	<b>RASC:</b> Resource Adequacy Sub-Committee	<b>WADC:</b> Wide Area Damping Controller
<b>EMS:</b> Energy Management System	<b>M2M:</b> Market to Market	<b>RBDC:</b> Reliability Based Demand Curve	<b>WAMS:</b> Wide Area Monitoring System
<b>EMT:</b> Electromagnetic Transient	<b>MHEB:</b> Manitoba Hydro-Electric Board	<b>RIIA:</b> <a href="#">Renewable Integration and Impact Study</a> (MISO)	<b>WECC:</b> Western Energy Coordinating Council
<b>ENTSO-E:</b> European Network of Transmission System Operators for Electricity	<b>MISO:</b> Mid-Continent Independent System Operator	<b>RoCoF:</b> Rate of Change of Frequency	<b>WI:</b> Western Interconnection
<b>ERZ:</b> External Resource Zone	<b>MOPI:</b> Michigan-Ontario PAR Interface	<b>RRA:</b> Regional Resource Assessment (MISO)	<b>ZRC:</b> Zonal Resource Credits
<b>FERC:</b> Federal Energy Regulatory Commission	<b>MRI:</b> Marginal Reliability Impact (modeling)	<b>RT:</b> Real-Time	



## GLOSSARY

Where possible, definitions have been sourced from [MISO's Tariff](#), [Business Practice Manuals](#), and NERC standards.

**AFC (Available Flowgate Capability):** A measure of the flow capability remaining on a Flowgate for further commercial activity above already committed uses. Values are time and service type dependent.

**Ancillary Services:** Those services that are necessary to support Capacity and the transmission of Energy from Resources to Loads while maintaining reliable operation of the Transmission System in accordance with Good Utility Practice.

**Asynchronous:** power systems or resources not synchronized in frequency or phase.

**CIL (Capacity Import Limit):** The amount of Planning Resources in MWs for an LRZ or ERZ determine by the Transmission Provider that can be reliably exported from that LRZ or ERZ for each Season.

**CEL (Capacity Export Limit):** The amount of Planning Resources in MWs for an LRZ or ERZ determine by the Transmission Provider that can be reliably exported from that LRZ or ERZ for each Season.

**Clogger (Constraint Logger):** The Energy Management System module which the Reliability Coordinators use to track, manage, and deactivate constraints in the Real-Time Market.

**Converter-Driven Stability:** instability caused by interactions between the control systems of electronic converters and the grid, potentially causing voltage or current oscillations, among other issues

**Co-optimization:** part of the grid management algorithm to simultaneously optimize multiple, related objectives (cost, availability, and reliability)

**CROW (Control Room Operations Window):** An application used by Operations Planning (formerly known as Outage Coordination) department to manage all internal (MISO) and external Reliability Coordinators equipment outages.

**CTS (Coordinated Transaction Scheduling):** Optimizes the efficiency of the interchange transactions at the MISO/PJM SEAM, and mitigates operational risks associated with significant NSI volatility.

**DA (Day Ahead) / RT (Real-Time) Markets:** MISO's DART system consists of two time-dependent markets, the Day Ahead (DA) and the Real Time (RT). The Day-ahead Energy Market (DA) is a forward market in which hourly Locational Marginal Pricing (LMP) values are calculated for each hour of the next operating day.

**Direct Loss of Load Capacity Accreditation Method:** MISO's capacity accreditation method, which via modeling analysis, evaluates a resource's performance during the most critical, high-risk hours of the year.

**Fast Active Power:** Grid-level service that rapidly injects or absorbs active power to stabilize the electrical grid and prevent larger disruptions.

**Flow Gate:** A representative modeling of a facility or group of facilities that may act as a constraint to power transfer on the Bulk Electric System.

**FTR (Financial Transmission Rights):** A financial instrument held by Market Participants to protect against paying congestion charges for scheduled injections and withdrawals. FTR values are determined by transmission congestion charges that arise in the Day-Ahead Energy and Operating Reserve Market.

**Interregional:** In the context of this document, demand, resources or transmission outside MISO's footprint, across a seam.

**Intra-Regional:** In this context, demand, resources or transmission within MISO's footprint.



**LMP (Locational Marginal Price):** Market clearing price for energy at a given location that is equal to the cost of supplying the increment of load at that location.

**LOLE (Loss of Load Expectation):** Expected or average number of days during a given period for which the available generation capacity is insufficient to serve demand. The industry has generally accepted an LOLE target of 1-day-in-10 years.

**MSSC (Most Severe Single Contingency):** A hypothetical event in an electric power system that would result in the greatest loss of resource output in megawatts (MW). The MSSC is calculated based on real-time system conditions and is a key benchmark for grid operators to ensure sufficient backup power to recover from a significant disturbance.

**Oscillation Damping:** Damping is a process of removing energy from a system. In an oscillating system, oscillations gradually decrease in size over time until the system comes to rest.

**PMU (Phasor Measurement Unit):** A device used in electrical grids to measure detailed characteristics of voltage and current in real-time.

**PRA (Planning Resource Auction):** The annual Planning Resource Auction is to ensure MISO has sufficient Planning Resources in its Local Resource Zones (LRZ). Import and export capabilities with external systems are considered in MISO's PRA indirectly through both firm and non-firm external support.

**PRM (Planning Reserve Margin):** The percentage above forecasted Coincident Peak Demand of Planning Resources for the Transmission Provider Region to meet the Loss of Load Expectation (LOLE), including a quantity sufficient to cover transmission losses.

**Planning Reserve Margin Requirement:** The amount of Zonal Resource Credits (ZRCs) required of each Load Serving Entity (LSE) with Coincident Peak Demand in a Local Resource Zone (LRZ) to meet the LSE's Resource Adequacy Requirements.

**Resonance Stability:** Ability to control oscillations and avoid voltage fluctuations, which can cause system instability and equipment damage.

**RA Hours:** minimum number of Resource Adequacy (RA) Hours for each season. Resource adequacy Hours are determined by evaluating historical operating data from the prior three years and are published prior to the annual Planning Resource Auction (PRA).

**Resource Adequacy:** the ability of the bulk electric system to serve electricity demand while also providing enough excess supply to achieve a threshold level of grid reliability.

**Rotor Angle (Power Angle):** angle between the internal electromotive force of the generator and its terminal voltage, which determines the amount of real power generated. Maintaining a stable rotor angle is critical for grid stability and enables multiple generators to operate in sync.

**Runback:** a power control strategy where electricity output is reduced in response to certain operational conditions or system demands.

**SE (State Estimator):** A computer model that computes the state (voltage magnitudes and angles) of the transmission system using the network model and real-time measurements.

**Shadow Price:** the marginal value of a resource or constraint; quantifying the economic impact of limitations.

**STATCOM (Static Synchronous Compensator):** electronic device that continuously controls reactive power to regulate and stabilize voltage on a transmission network.



**TCR (Transmission Congestion Right):** a financial tool to allow market participants to hedge against price volatility caused by congestion.

**Thermal Overload:** condition where a motor can draw too much current (e.g., from increased load or voltage fluctuations), which can lead to overheating with potential to damage the equipment

**Thyristors:** solid state switches that can be switched on by adjusting the firing angle at a precise point in the AC waveform when the device is forward-biased (i.e., when the converter has positive voltage across its terminals).

**TLR (Transmission Loading Relief):** An interregional congestion management process that assesses external impacts on congestion, used across the eastern interconnection.

**UFLS (Underfrequency Load Shedding):** Automatic programs designed to protect the grid and prevent cascading blackouts when the system's frequency falls below safe operating limits. The main NERC standard governing these programs is [NERC PRC-006](#).

**Weak Grid Area:** A less-resilient system that is more vulnerable to voltage and frequency fluctuations with changes in energy flow.

**ZDC (Zonal Deliverability Charge):** Benefit to an LSE from transmission investment shown to alleviate transmission congestion and, as a result, lower internal zonal capacity obligations.

---

**MISO thanks the National Lab of the Rockies (formerly National Renewable Energy Lab) for their contributions to this effort.**



# 9 Technical Appendix

## HVDC CONFIGURATIONS AND TOPOLOGIES

### HVDC MONOPOLE

In an HVDC monopole configuration, there is one conductor or cable generally used for long distance power transfer while the return path is provided by ground electrodes. In other cases where the ground electrode return is not a feasible solution, a metallic return path might be used.

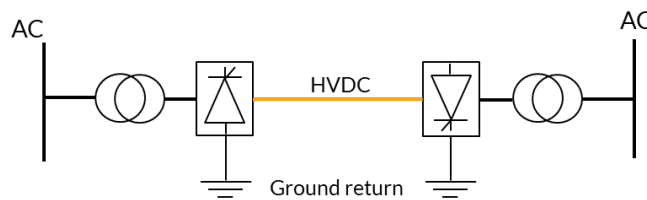

Figure 18: HVDC Monopole with ground return

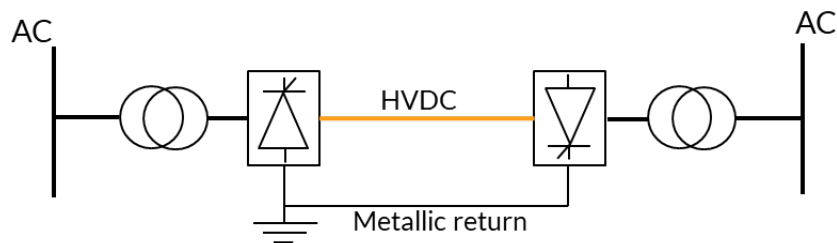

Figure 19: HVDC Monopole with metallic return

### HVDC BIPOLE

An HVDC bipole has two conductors, one positive and the other negative, such that the common return path is only used to carry a small, unbalanced current during normal operation. The return path can be provided by ground electrodes or a dedicated metallic return (DMR). The DMR is used for relatively short transmission distance due to increased cost with high distance transmission.

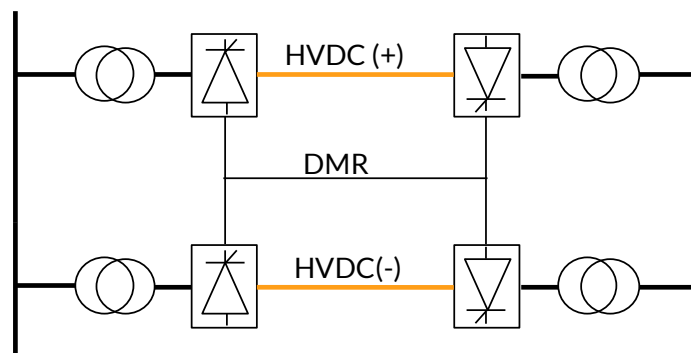

Figure 20. HVDC Bipole with dedicate metallic return

In an HVDC bipole, a sudden loss of one pole does not result in a total loss of transmission since partial power transfer can continue through the DMR. This inherent reliability of the bipole configuration, however, is constrained by the overload capacity of the remaining healthy pole.

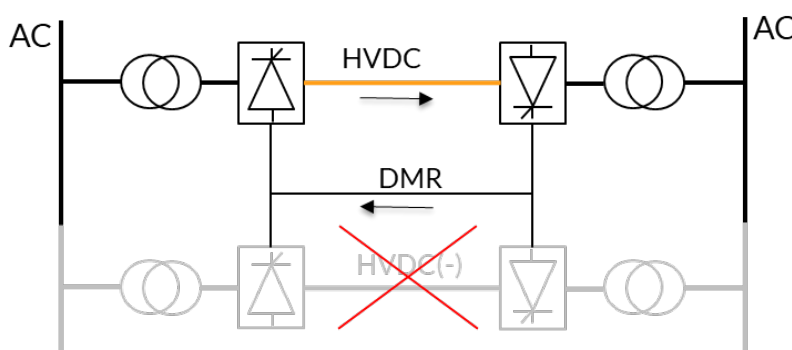

Figure 21: Inherent reliability of a bipole HVDC system

The Square Butte HVDC is an example of HVDC bipole in MISO footprint that connects power plant station in North Dakota to the Arrowhead converter station in Minnesota. The Manitoba Hydro system is another example of HVDC bipole system that synchronously connects to the MISO footprint using AC ties.

## BACK-TO-BACK CONVERTERS

In a back-to-back setting, the rectifier and inverter are in the same station and are mainly used for power transfer between two adjacent asynchronous AC grids. A back-to-back converter allows precise power transfer while keeping the two grids electrically independent. It decouples frequency control, preventing disturbances in one system from propagating to the other and thus enhancing reliability.

Within MISO footprint, the Mackinac back-to-back converter, located in Michigan's Upper Peninsula connects the Lower Peninsula and operate asynchronously. Beyond controlling power transfer between the two regions, the Mackinac converter plays a critical role in voltage regulation, reactive power support, and stability improvement for the relatively weak Upper Peninsula grid.

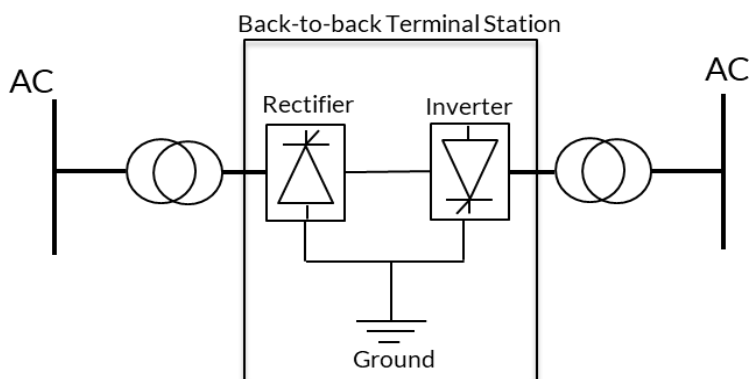

Figure 22: Back-to-back HVDC converter

## HVDC LINE TOPOLOGIES

### Two-Terminal HVDC Lines

A two-terminal HVDC system consists of two converter stations, one operating as a rectifier (AC to DC conversion) and the other as an inverter (DC to AC conversion), connected by a single DC transmission line. This configuration enables point-to-point power transfer between two geographically separated locations. It is the most common HVDC configuration being proposed in MISO footprint.

In point-to-point HVDC systems, there has not been strong need for installing dedicated DC circuit breakers as the DC faults are typically cleared through AC side isolation.

### Multi-Terminal HVDC Lines and Networks

A multi-terminal HVDC system interconnects three or more converter stations through a common DC network, allowing power to be exchanged among multiple regions. Each terminal can operate as a rectifier or inverter depending on system needs, with the total power supplied by rectifier stations equaling the total power absorbed by the inverter stations. This configuration offers greater flexibility but also introduces increased control and protection complexity. While multi-terminal HVDC systems can technically operate without DC circuit breakers, this means a fault anywhere on the DC network can de-energize the entire system. The use of HVDC circuit breakers could allow selective isolation of faulted sections, but these devices remain an evolving technology and are not currently part of MISO's planning considerations. From a planning perspective, two-terminal or, in limited cases, three-terminal HVDC configurations are the most practical considerations.

### DC Circuit Breakers (DCCBs)

The DC circuit breaker working principle is different than a conventional AC circuit breaker. During a short-circuit fault on an AC transmission line, the fault current offers zero crossings twice per cycle. For a 60 Hz system, this occurs 120 times per second. Conventional AC breakers are designed to take advantage of these natural zero crossings for arc extinction because at that instant, the dielectric strength of the medium between the breaker contacts is relatively higher.



In DC systems, no oscillation or natural zero crossings exist to assist interruption. Further, due to low DC link impedance, the fault current can reach extremely high levels within a few milliseconds, potentially damaging converters, cables, and other DC components. Artificial current zero-crossings must be created to enable fast current interruption. To slow down the rate at which fault current increases, DC reactors (DCRs) are placed in series with the line. These reactors increase system inductance that cause power losses during normal operation. They also increase system cost and complexity.

In DC grids with multiple converters and lines, selective fault clearing becomes critical and fast acting DCCBs are essential to isolate only the faulty section while allowing the rest of the DC grid to continue operating.

## MARKET IMPACT ASSESSMENT

### COMPARATIVE ANALYSIS OF HVDC MARKET INTEGRATION

#### North American RTO Market

Existing HVDC facilities across North America exhibit diverse operational characteristics shaped by BA relationships, institutional arrangements, and market integration approaches. Table 6 summarizes key HVDC facilities and their participation characteristics across North American RTOs. The patterns revealed in these implementations inform potential approaches for future HVDC integration.

Facility	RTOs/BAs	BA Relationship	RT Dispatch	Ancillary Services	Congestion Mgmt.	Loss Treatment
Trans Bay Cable	CAISO	Intra-BA	5-min SCED	No	Yes (co-optimized)	Not modeled explicitly
Pacific DC Intertie	CAISO, BPA	Inter-BA (async)	Hourly schedule	No	Limited	Loss-adjusted schedule
Neptune	PJM-NYISO	Inter-BA (sync)	Hourly (merchant)	No	No (load pocket)	Operator internalized
Cross Sound Cable	ISONE-NYISO	Inter-BA (sync)	Hourly e-Tag	Limited (voltage)	No (load pocket)	Operator internalized
Linden VFT	PJM-NYISO	Inter-BA (sync)	DA price-based	No	No	Operator internalized
Manitoba Hydro (EAR)	MISO-MH	Inter-BA (async)	5-min SCED	Yes (Reg, Reserves)	Yes (at proxy bus)	Operator internalized
Phase I/II	ISO-NE-HQ	Inter-BA (async)	Hourly e-Tag	Limited	No	Operator internalized

Note: RT = Real-time; DA = Day-ahead; Reg = Regulation; async = asynchronous; sync = synchronized

Table 6: HVDC Facility Characteristics in North American RTOs

#### Key Observations

- Intra-BA facilities like Trans Bay Cable can be integrated into 5-minute real-time dispatch because a single market operator controls both terminals.



- Synchronized inter-BA facilities face greater constraints. No example exists of synchronized inter-BA HVDC facilities receiving coordinated 5-minute economic dispatch from both RTOs.
- Asynchronous inter-BA connections demonstrate greater flexibility. MISO EAR model enables Manitoba Hydro to participate in 5-minute SCED despite the asynchronous connection.
- Ancillary service participation correlates strongly with dispatch integration. Synchronized inter-BA facilities generally do not provide ancillary services.
- Congestion hedging products are available only within single RTO footprints. No cross-BA congestion hedging products exist for inter-BA HVDC facilities.
- Despite the non-linear, direction-dependent nature of HVDC losses, no US RTO models these losses explicitly in real-time LMP calculations.

## **Global HVDC Integration**

### **Australia**

In Australia's National Electricity Market (NEM), HVDC facilities like Directlink and Murraylink are treated as dispatchable resources with 5-minute dispatch targets co-optimized with generation and load. HVDC losses are calculated every 5 minutes but not modeled as non-linear functions in dispatch. AEMO applies specialized procedures for ramping and frequency control, including linear ramping via AGC with 4-second updates.

### **Europe**

HVDC interconnectors such as IFA (UK-France), BritNed (UK-Netherlands), and Nemo Link (UK-Belgium) are integrated through Single Day-Ahead Coupling (SDAC) and Single Intraday Coupling (SIDC) frameworks. HVDC losses are allocated using pro-rata or marginal loss factors in settlement rather than modeled in dispatch engines. This approach illustrates forward market coordination across sovereign boundaries without real-time nodal dispatch.

## **TECHNICAL FORMULATIONS FOR INTRA-REGIONAL HVDC**

### **Circular Flow Analysis**

Circular flow between AC and HVDC paths can occur under both fixed and dispatchable operations when optimization attempts to manage congestion or respond to loss differentials. NLR research identifies three distinct mechanisms that can cause circular flow

### **Linear Loss Approximations**

MISO's SCUC and SCED models use linear approximations to represent transmission losses. These work reasonably well for incremental AC dispatch but can be inaccurate with large HVDC flow changes. Because HVDC can shift hundreds of megawatts rapidly, it can move the system far from the linearization point, making loss estimates inaccurate. This can lead the optimization to dispatch HVDC in ways that appear economic under the linear model but are suboptimal when actual non-linear losses are considered. Two issues are observed with initial studies:



Issue 1: Large deviations between AC power flow solutions and linear approximations may lead to inaccuracies or oscillations. Dispatchable HVDC may cause greater deviations from the linear approximation.

Issue 2: Under a linear approximation, losses become negative when flow reverses direction, whereas in reality, losses increase with the absolute value of flow. This inaccurate linear loss model can lead to circular flows and large errors in SCUC/SCED loss calculations.

### Negative Prices and Loss Maximization

Negative LMPs (often driven by renewable generation with production tax credits or must-run status) can lead to counterintuitive outcomes. Under negative pricing, losses take on negative economic value, meaning the system is effectively paid to consume energy. The optimization may favor increased losses, interpreting them as cost-reducing. This can create circular flows between HVDC and AC lines, where power loops through the system to inflate losses. Case studies show this can emerge under both fixed and dispatchable HVDC schedules.

### AC Congestion Management

Even under positive prices, circular flows between AC and HVDC paths can emerge when optimization manages AC congestion. Research illustrates how congestion on specific AC corridors leads to HVDC dispatch patterns that create circular flows. These solutions are economically rational (they reduce congestion at lower cost) but result in complex power flow patterns. The issue is more likely when HVDC connects regions that also have strong AC ties.

### Piecewise Linear HVDC Loss Formulation

A piecewise linear (PWL) loss model provides a practical approach that balances computational tractability with necessary accuracy for optimal dispatch. Under this approach, the HVDC loss characteristic is approximated as a series of linear segments.

In the following formulation,  $hl_{i,h}$  is the HVDC losses under “from end MW”  $H_{from,h} = hf_{i,h}$ .  $hf_{i,h}$  may be positive or negative. But  $hl_{i,h}$  is non-negative. HVDC “to end MW” is  $H_{to,h}$ . The following piece wise linear formulation uses continuous variables. It can solve HVDC losses at the correct segment when price is positive. The index for HVDC is  $h = 1, \dots, N_h$

$$H_{to,h} = H_{from,h} - HLoss_h \quad h = 1, \dots, N_h$$

$$H_{from,h} = \sum_{i=1}^m w_{i,h} hf_{i,h} \quad h = 1, \dots, N_h$$

$$HLoss_h = \sum_{i=1}^m w_{i,h} hl_{i,h} \quad h = 1, \dots, N_h$$

$$\sum_{i=1}^m w_{i,h} = 1 \quad h = 1, \dots, N_h$$

$$w_{i,h} \geq 0, \text{ for } i = 1, \dots, m \quad h = 1, \dots, N_h$$



However, when price is negative, it maximizes losses and solves at the highest loss segment even if the HVDC flow is solved at the lower segment. Theoretically, binary variables need to be introduced to ensure the correct solution. Given the small number of HVDC lines, the impact from adding binary variables in SCUC is expected to be small. Adding binary variables in SCED may cause solution time increase. Heuristic methods may be developed to mitigate the issue.

### HVDC Settlement Formulations

The market clearing identity includes a term for HVDC flows that reflects the net economic impact of transferring power across regions. This can be expressed as:

$$\sum_{g=1}^{N_g} P_g LMP_{b_g} - \sum_{b=1}^{N_b} L_b LMP_b - \sum_{l=1}^{N_l} T_{max,l} \mu_l + \sum_{h=1}^{N_h} (H_{to,h} LMP_{to,h} - H_{from,h} LMP_{from,h}) = 0$$

where,

$P_g$ : Cleared generation cleared at generation  $g$  located at bus  $b_g$

$l_b$ : Load at bus  $b$

$T_{max,l}$ : Limit of AC transmission constraint  $l$

$\mu_l$ : Shadow price of constraint  $l$

$H_{from,h}$  and  $H_{to,h}$ : HVDC flow at the sending and receiving ends of HVDC line  $h$

$LMP_{from,h}$  and  $LMP_{to,h}$ : LMPs at the HVDC terminals

This identity ensures that the total payments by load equal the payments to generators, plus congestion rents from AC and HVDC flows.

The net settlement is the HVDC-specific term in the power balance:

$$Net\ Settlement_h = \sum_{h=1}^{N_h} (H_{to,h} LMP_{to,h} - H_{from,h} LMP_{from,h})$$

### Key Settlement Implications

- When HVDC is not binding at its limit, the net settlement term may be zero, and the cost of HVDC losses may be reflected in AC congestion rents.
- When HVDC is binding at the limit, the net settlement term may not be zero. Additional settlement rules may be needed, either through direct HVDC settlement or other allocation mechanisms.
- This formulation ensures HVDC flows are treated consistently with other transmission elements, with the cost of HVDC losses and value of congestion relief fully reflected in market outcomes.

### Potential Mitigation Strategies

Several enhancements to SCED and SCUC formulations are being researched to address circular flow and loss modeling challenges:



### *Piecewise Linear and Hybrid Loss Models*

HVDC losses can be modeled using PWL formulations with either continuous or binary variables. Continuous models may suffice under positive prices, but binary variables may be needed to prevent incorrect segment selection under negative LMPs. Given the small number of HVDC lines, computational impact in SCUC is expected to be manageable.

### *Integer Variable Methods for Flow Direction*

To improve flow direction optimization and avoid oscillatory solutions, integer or binary variables can be introduced to explicitly model flow direction. This provides more stable solutions when HVDC flow reversals occur.

### *Circular Flow Detection and Fallback Logic*

Software tools can be implemented to detect circular flows in AC or HVDC paths. When such flows are identified, the optimization can revert to fixed-loss models or apply corrective constraints to eliminate the economic incentive for loss-maximizing behavior. Losses would be fixed at expected values based on forecasted loading rather than optimized as variables.

### *Angle Difference Constraints*

Bus angle difference constraints between HVDC terminals can effectively mitigate circular flows. These constraints can be derived from HVDC bus angle difference to bus injection sensitivities and incorporated into SCED/SCUC. Preliminary studies show this approach can be effective. Additional tools may be needed to identify angle or flow limits based on voltage or transient stability considerations.

## **INTERREGIONAL COORDINATION AND PARTICIPATION**

### **Coordination mechanisms by neighboring balancing authority**

The applicability of coordination mechanisms varies significantly across MISO's neighboring Balancing Authorities, depending on market structure, regulatory jurisdiction, and existing coordination agreements. Table 7 summarizes coordination mechanisms in place with each neighbor.

Neighbor	BA Type	Coordination Mechanism	Market-Based?	HVDC Today?	Coordination	HVDC Integration Considerations
<b>Manitoba Hydro</b>	Synchronized (Asynchronous Source)	EAR Model (Dynamic Scheduling)	Partial	Yes	Medium	Manitoba's HVDC is internal to its own system; asynchronous with MISO; not generalizable to synchronous HVDC
<b>TVA / AECI</b>	Synchronized, Non-Market	Bilateral Scheduling + TLR	No	No	Low	HVDC would be limited to fixed schedules; no redispatch capability
<b>PJM</b>	Synchronized, Market	M2M + CTS	Yes	No	High	Framework exists; enhancements needed for dynamic HVDC dispatch
<b>SPP</b>	Synchronized, Market	M2M Only	Yes	No	Medium-High	Similar to PJM; lacks CTS; modeling differences may affect HVDC
<b>IESO</b>	Synchronized, Market (Non-FERC)	PAR Coordination	Partial	No	Medium	Coordination possible, but limited by jurisdiction and lack of M2M

**Table 7: Interregional Coordination Mechanisms by Neighboring BANLR research on interregional coordination**



NLR is developing foundational software and coordination methods to evaluate the impact of different coordination configurations at different operational stages. The Sienna Decomposition platform provides capability to study distributed coordination algorithms across RTOs.

#### *Key Capabilities*

- Benchmark optimal mathematical models for each configuration with detailed representation of multi-RTO market clearing, area interchange, transmission loop flow, and both intra- and interregional HVDC dispatch
- Multi-stage simulation with flexibility to study different configurations at different stages (day-ahead, real-time)
- Consistent measurement of economic and reliability impacts through emulation functions that retrieve dispatch results from different grid operators and calculate pre- and post-contingency flows

### **REAL-TIME COORDINATION METHODS**

Real-time market coordination between two RTOs is generally implemented in distributed fashion. RTOs exchange shadow prices, relief requests, or price curves to achieve dispatch, flow, and price convergence. However, limited information exchange and time delays may cause convergence issues or sub-optimal solutions.

#### **Coordination Approaches**

##### *RT1: Shadow Price and Relief Request Exchange*

Used in existing MISO-PJM and MISO-SPP M2M coordination. Requires minimal information exchange but has limitations: (1) Shadow prices indicate which side can provide lower-cost relief but do not quantify how much cheaper relief could be provided; (2) Fixed relief requests may cause 'chattering' or 'oscillation' issues, exacerbated by communication delays; (3) Determining relief requests based solely on SCED solutions is not straightforward; a shadow price curve showing the relationship between requested relief and shadow price could provide more useful information.

##### *RT2: Price Curve Exchange*

Used in ISO-NE and NYISO Coordinated Transaction Scheduling. Net interchange is modeled as injections and withdrawals at proxy interface buses. ISO-NE generates forecast price curves that NYISO uses to clear CTS bids. However, price forecast errors and network congestion may cause counter-intuitive flows.

##### *RT3: Marginal Equivalent Method*

Proposed by ISO-NE to exchange marginal resources and incorporate them into neighboring RTO market clearing. This represents the neighboring RTO through its marginal units, providing more accurate reflection of power balance and transmission constraint impacts. However, identifying marginal units and co-optimizing reserves can be challenging.

##### *RT4: Enhanced M2M with Relief Cost Curves*



NLR research proposes improvements to existing M2M methods: (1) Improvement of shadow price and relief request calculation methods to address oscillation issues; (2) Generating and exchanging price curves for each coordinated M2M transmission constraint, with each RTO including price curves from neighboring RTOs in its SCED optimization.

## RELIABILITY OPERATIONS IMPACT ASSESSMENT

### ANGULAR STABILITY SUPPORT

Figures 23 and 24 below illustrates the relative phase angle trajectories of major buses in a simplified 176-bus model of WECC. The bus angle trajectories are from a 4-cycle Single Line to Ground (SLG) fault cleared at 0.67 seconds. Figure 24 presents the same fault scenario in Figure 23, but with an immediate 500 MW transfer through HVDC lines. The added HVDC transfer appears to reduce the overall angular separation among the buses.

A high angular separation drives current flow that sometimes cause protective relays to trip on overloads, potentially causing cascading outages. Engineers at the Bonneville Power Administration (BPA) demonstrated that small angle differences caused by a fast power change on an HVDC link could have prevented the Dec. 14, 1994, blackout in the WECC.<sup>24</sup>

---

<sup>24</sup> Rovnyak, S.M. & Taylor, C.W. & Mechenbier, J.R. & Thorp, J.s. (1995). Plans to Demonstrate Decision Tree Control Using Phasor Measurement for HVDC Fast Power Changes.

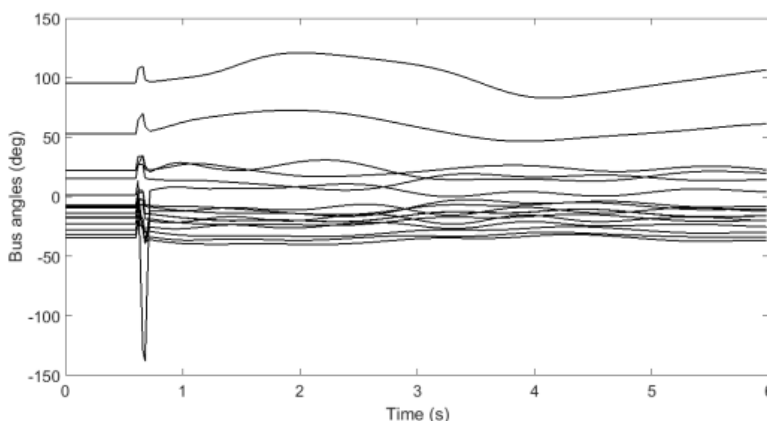

Figure 23: Relative phase angle difference for a 4-cycle Single Line-to-Ground fault

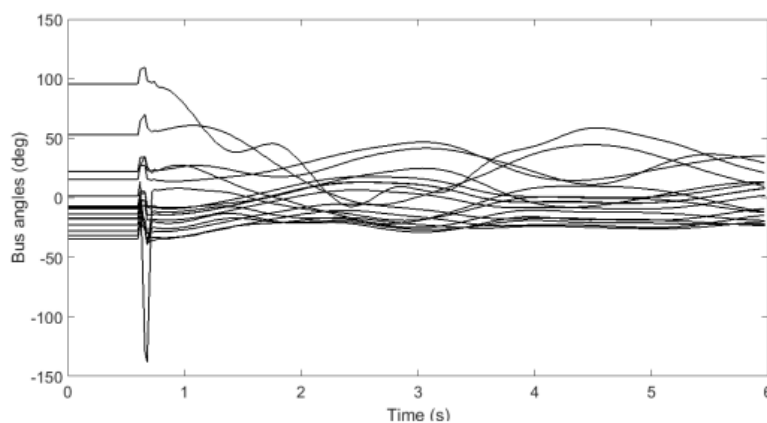

Figure 24: Relative phase angle difference for the same fault in Figure 6 with a 500 MW HVDC transfer

## CASE STUDY: STABILITY BENEFITS OF HVDC

### Pacific DC Intertie (PDCI)

The Pacific DC Intertie, a  $\pm 500$  kV, 3,100 MW HVDC transmission line connecting Oregon and California, provides a notable example of active damping control.<sup>25</sup> Since 2017, the system has operated with a Wide Area Damping Controller (WADC) that uses real-time phasor measurement unit (PMU) feedback to target inter-area oscillations, particularly the North-South "B mode" oscillation around 0.3 Hz. This implementation has proven effective, significantly enhancing the damping of system oscillations without negatively affecting other system modes. The PDCI demonstrates how HVDC technology, when equipped with advanced control systems, can be successfully integrated into wide-area stability enhancement strategies.

### Rio Madeira and Xingu HVDC Systems

Brazil's large-scale HVDC projects—the Rio Madeira and Belo Monte (Xingu) systems— highlight the role

---

<sup>25</sup> Pierre, Brian & Wilches-Bernal, Felipe & Schoenwald, David & Elliott, Ryan & Trudnowski, Daniel & Byrne, Raymond & Neely, Jason. (2019). Design of the Pacific DC Intertie Wide Area Damping Controller. IEEE Transactions on Power Systems. PP. 1-1. doi: 10.1109/tpwrs.2019.2903782.



of HVDC in enhancing power system stability.<sup>26</sup> The Rio Madeira project consists of two  $\pm 600$  kV bi-poles rated at 3,150 MW each, while the Xingu system includes two  $\pm 800$  kV bi-poles, each rated at 4,000 MW. It is worth noting that the Madeira bipoles are interconnectors, while both the Xingu-Estreito and Xingu-Terminal Rio are embedded HVDC systems.

The Xingu HVDC systems offer a strategic transfer path for renewable generation from the Northeast (NE) to the Southeast (SE) load centers. In situations where AC corridors from the NE to SE are saturated or compromised, the Xingu HVDC links provide an alternate, controllable route for balancing regional surpluses and deficits. In this context, the bipoles act as flexible, high-capacity relief valves for the AC network, increasing dispatch efficiency under high IBR penetration.

Both systems are equipped with sophisticated master control schemes designed for coordinated operation. These control systems incorporate oscillation damping capabilities, allowing the HVDC links to support the AC network not only in steady-state power transfer but also in stabilizing dynamic disturbances. Studies and integration tests have shown that excluding the power oscillation damping logic leads to loss of damping and potential instability in oscillatory electromechanical modes, especially after major contingencies.

### **Itaipu HVDC System**

The Itaipu HVDC system ( $\pm 600$  kV) allows the full exploitation of the 50 Hz generation from the Paraguayan share of Itaipu, which would otherwise be limited due to asynchronous frequency and load constraints in Paraguay. Since the Paraguayan system operates at 50 Hz, its surplus power is sent to Brazil's 60 Hz system using the HVDC link without causing frequency instability.

### **INELFE France-Spain VSC links**

The INELFE project, connecting France and Spain via two 1,000 MW VSC links, was designed to strengthen the interconnection across a natural bottleneck in the European grid.<sup>27</sup> The project addressed challenges associated with maintaining voltage and frequency stability across two independently operated synchronous areas. The VSC terminals are configured not only to transmit power but also to provide ancillary services including voltage control, frequency response, and black-start capability. To further enhance stability, the system uses AC emulation and custom-designed protection schemes that allow it to dampen inter-area oscillations. Since its commissioning in 2015, INELFE has reliably supported system recovery after faults and improved dynamic voltage response between the Iberian Peninsula and the rest of Europe.

### **NordLink HVDC**

Commissioned in stages between 2019 and 2021, the NordLink HVDC line connects hydro-rich Norway with Germany's variable renewable-heavy grid.<sup>28</sup> One of the first large-scale point-to-point VSC-HVDC links in Europe, NordLink was designed with voltage stability as a key operational objective. During initial

---

<sup>26</sup> Macleod, N., Kayibabu, B., Sellick, Rob & Kirby, Neil. (2010). [A  \$\pm 600\$ kV HVDC Transmission project to access remote renewable energy sources.](#)

<sup>27</sup> Entsoe, HVDC Links in System Operations, Technical Paper. December 2019. [https://eepublicdownloads.entsoe.eu/clean-documents/SOC%20documents/20191203\\_HVDC%20links%20in%20system%20operations.pdf](https://eepublicdownloads.entsoe.eu/clean-documents/SOC%20documents/20191203_HVDC%20links%20in%20system%20operations.pdf)

<sup>28</sup> CIGRE Science and Engineering, CSE No 27 – January 2023. B4 – Transmission system testing of a VSC based HVDC system. <https://cse.cigre.org/cse-n027/b4-transmission-system-testing-of-a-vsc-based-hvdc-system.html>



commissioning, the converters were tested in STATCOM mode - operating with full reactive power capability without transmitting active power. This ensured the link could provide voltage support even when one or both poles were not transferring active power. Selected pole performed controlled ramping to monopolar operation over three seconds while continuing to provide reactive power, thereby maintaining AC voltage stability during the transient.

### INTEGRAL SQUARE BUS ANGLE (ISBA) INDEX

The ISBA index quantifies the overall network stress by measuring the voltage phase angle differences of the system.<sup>29</sup> Prior to the calculation, the bus angle trajectories must be unwrapped to eliminate discontinuities at +/- 180 degrees. The selected set of buses does not need to cover the entire system but should include representative nodes from all major areas. At each time step, the Square Bus Angle (SBA) index is first computed as-

$$SBA(t) = \sum_i M_i (\theta_i(t) - \theta_{coa}(t))^2 \quad (9.1)$$

$$\theta_{coa}(t) = \frac{\sum_i M_i \theta_i(t)}{\sum_i M_i} \quad (9.2)$$

where  $\theta_i(t)$  represent continuous trajectories reconstructed from the bus angles and constants  $M_i$  are weighing factors that reflect the relative importance of different locations. The ISBA index is then obtained by integration  $SBA(t)$  over time either by using a sliding window or a low pass filter.

A higher ISBA value indicates greater overall angular separation between buses, signifying a more stressed system that is operating closer to instability.

### SHORT-CIRCUIT RATIO (SCR) TEST

A SCR test is used to evaluate how well a converter can operate and remain stable when connected to a weak AC grid. In an HVDC system, a weak grid can be simulated by increasing the impedance between the converter's POI bus and the AC network, thereby reducing the short-circuit ratio (SCR) as seen by the converter. Initially at the steady state, the line impedance between bus 4 and bus 7 in Figure 25 is modified so that the HVDC system operates with SCR = 20 (very strong grid). During the simulation, SCR is gradually reduced to emulate the weaker grid conditions as follows:

Time (s)	SCR Value	Grid Strength
----------	-----------	---------------

<sup>29</sup> S. M. Rovnyak, M. N. Nilchi, D. W. Longbottom and D. C. Vasquez, "Angle stability predictive indices," 2012 IEEE Power and Energy Society General Meeting, San Diego, CA, USA, 2012, pp. 1-6, doi: 10.1109/PESGM.2012.6344976



0-1	20	Very strong
1-5	5	Moderately strong
5-10	3	Weak
10+	1.5	Very weak

Table 8: Variable SCR test

At each SCR level, the corresponding impedance is computed and applied to the line connecting the inverter to the AC grid. Results show that for a very weak grid, the system experience high oscillations, especially immediately after changes in the grid strength, indicating the limit of stable operation. The test VSC-HVDC converter is injecting the desired 400 MW real power into the AC system despite those oscillations during the lowest SCR scenario.

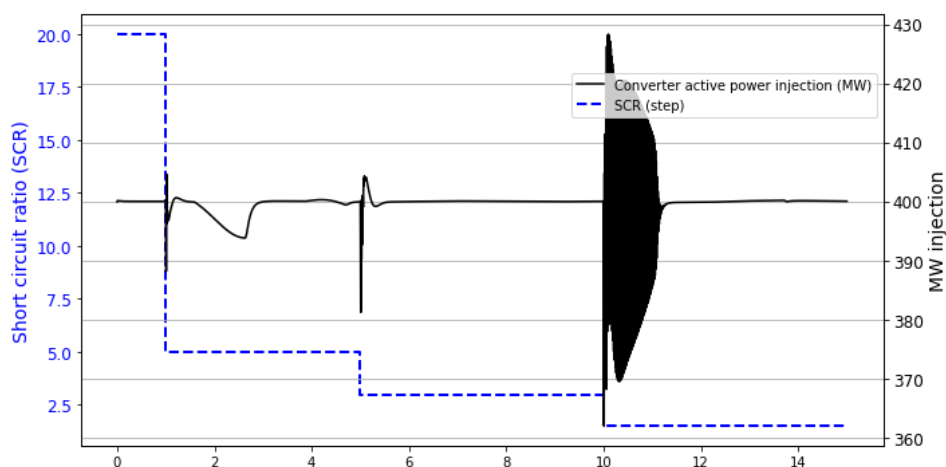

Figure 25: Converter active power injection (MW) under varying SCR

The tests performed here serve as a proxy for evaluating the robustness of HVDC converters. MISO's 2023 attributes analysis mentions that while SCR remains a useful preliminary screening tool for assessing converter's stability as simulated above, it may not fully capture grid strength under high IBR penetration, requiring the use of a new 'dynamic impedance' method.<sup>30</sup> In practice, system operators or planning teams may require project developers to submit validated dynamic models of their converters. These models enable the stability analysis team to conduct critical tests such as voltage and frequency ride-throughs and weak grid assessments.

## PLANNING IMPACT ASSESSMENT

**Maximum Power Transfer Limit of AC Lines.** Every load carrying series impedance branch has a maximum power transfer limit. An accurate approximation of the real power transfer through a purely

<sup>30</sup> [MISO Attributes Roadmap Technical Appendix](#)



reactive impedance branch (i.e., a branch where branch resistance is neglected) is given by equation (1) below:

$$\text{RPT} = |V_s| |V_r| \sin(\theta) / |X_{Br}| \quad (1)$$

Where

RPT = Real Power Transfer through Branch in per unit

$V_s$  = Sending-end Terminal Voltage in per unit

$V_r$  = Receiving-end Terminal Voltage in per unit

$X_{Br}$  = Series Reactive Impedance of Branch in per unit

$\theta$  = Angle in degrees or radians by which the voltage at the sending-end terminal leads the voltage at the receiving-end terminal.

In the equation above, real power losses are ignored, so real power transferred into the sending-end terminal of the branch is equal to real power transferred out of the receiving-end terminal of the branch.

A maximum power transfer limit can be established for a reactive impedance branch based on equation (1) by assuming the angular difference between the sending-end terminal voltage and receiving-end terminal voltage is  $90^\circ$  since the maximum value of  $\sin(\theta)$  is 1.0 and occurs at an angle of  $90^\circ$ . The formula for the maximum power transfer limit of an impedance branch is thus given by equation (2) below:

$$\text{MPTL}_{\text{Branch}} = |V_s| |V_r| / |X_{Br}| \quad (2)$$

Where

$\text{MPTL}_{\text{Branch}}$  = Maximum Real Power Transfer through Branch in per unit

For a transmission line circuit branch or transmission transformer branch that can be modeled as a series reactance within a power system, equation (2) is a true hard limit for the transmission line circuit branch or transmission transformer branch, but not necessarily the most conservative maximum power transfer limit if  $X_{Br}$  represents the reactive impedance of just the branch and  $V_s$  and  $V_r$  represent the voltages at the sending-end and receiving-end terminals of the branch respectively. That is, the true maximum power transfer limit must consider both the characteristics of the transmission branch in question as well as the characteristics of the rest of the system.

To understand the overall system impact on the maximum power transfer limit of a single transmission branch, consider the branch and system equivalent illustrated in Figure 26 below.

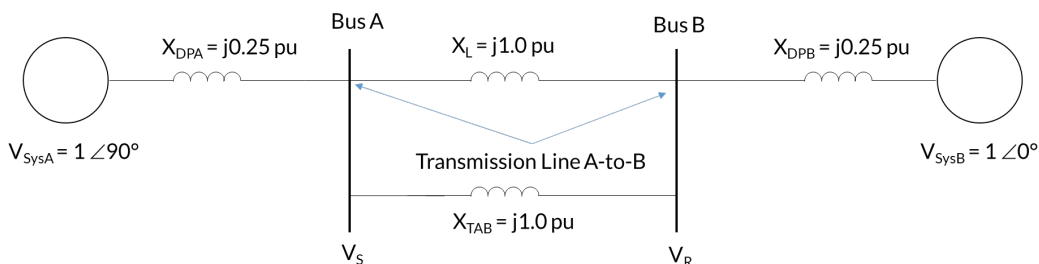

Figure 26: Impedance Branch and Equivalent System

Per Figure 26, a single transmission branch exists between Bus A and Bus B and is represented by the reactive impedance  $X_{Br}$ . The rest of the system is modeled via an adjusted transfer impedance<sup>31</sup> between Bus A and Bus B ( $X_{AdjTranAB}$ ), equivalent source impedances at both Bus A and Bus B ( $X_{EqScA}$  and  $X_{EqScB}$  respectively) and equivalent independent voltage sources behind each equivalent source impedance whose magnitudes and angles are set to replicate real power transfer from Source A (acting as a generator) and Source B (acting as a load) and are designated as  $V_{SysA}$  and  $V_{SysB}$  respectively.

The magnitude of the total transfer impedance<sup>32</sup> between Bus A and Bus B is based on the parallel combination of the transmission branch impedance ( $X_{Br}$ ) and the adjusted transfer impedance ( $X_{AdjTranAB}$ ) between the buses and is equal to  $j0.5$  per unit (i.e.,  $j1.0 || j1.0 = j0.5$ ). The sum of the two equivalent source impedances ( $X_{EqScA}$  and  $X_{EqScB}$ ) is also equal to  $j0.5$  per unit (i.e.,  $j0.25 + j0.25 = j0.5$ ). The maximum real power transfer from Source A to Source B is limited by the total equivalent system impedance between the two equivalent sources (which is the sum of the two equivalent source impedances and the total transfer impedance between Bus A and Bus B). The total equivalent reactance between the two sources is designated as  $X_{TotSys}$  and is equal to  $j1.0$  per unit (i.e.,  $j0.25 + j0.5 + j0.25 = j1.0$ ). The maximum real power transfer from Source A to Source B is determined based on an angular displacement between the Equivalent Source A voltage and the Equivalent Source B voltage of  $90^\circ$  and is designated as  $MPTL_{System}$ . Using equation (2) and substituting  $V_{SysA}$ ,  $V_{SysB}$  and  $X_{TotSys}$  for  $V_S$ ,  $V_R$  and  $X_{Br}$  respectively yields the following:

$$MPTL_{System} = |V_{SysA}| |V_{SysB}| / |X_{TotSys}| = (1.0)(1.0) / 1.0 = 1.0 \text{ per unit} \quad (3)$$

Where

$MPTL_{System}$  = Maximum Real Power Transfer across System in per unit

$V_{SysA}$  = Equivalent source voltage at Bus A terminal in per unit

$V_{SysB}$  = Equivalent source voltage at Bus B terminal in per unit

$X_{TotSys}$  = Equivalent total system reactance between equivalent voltage sources in per unit

<sup>31</sup> The term *adjusted transfer impedance* corresponds to the transfer impedance that would exist if the transmission branch in question were out of service, thus allowing the transmission branch impedance to be modeled separately.

<sup>32</sup> The term *total transfer impedance* corresponds to the transfer impedance that would exist if the transmission branch in question were in service, so *total transfer impedance* is the true transfer impedance for a two-bus equivalent model.



Because in this example the transmission branch impedance is equal to the adjusted transfer impedance between Bus A and Bus B (i.e., the transfer impedance between Bus A and Bus B with the transmission branch removed), it can be inferred that 50% of the maximum power transfer between Source A and Source B will flow in the transmission branch while the remaining 50% of the maximum power transfer between Source A and Source B will flow through the adjusted transfer impedance based on simple current division. Therefore, in this particular case, the maximum power transfer limit for the transmission branch with consideration given to the impact of the external system, which is designated as  $MPTL_{\text{BranchSystem}}$ , is 0.5 per unit, or 50% of  $MPTL_{\text{System}}$  based on equal current division between the impedance branch and the parallel adjusted transfer impedance.

The maximum power transfer limit of just the branch (i.e.,  $MPTL_{\text{Branch}}$ ) without consideration of the external system is calculated as follows:

$$MPTL_{\text{Branch}} = |V_S| |V_R| / |X_{Br}| = (1.0)(1.0) / 1.0 = 1.0 \text{ per unit} \quad (4)$$

Therefore, while the maximum power transfer limit calculated for the branch without regard to the external system (i.e.,  $MPTL_{\text{Branch}}$ ) is a valid limit, it is not necessarily the most conservative limit. In this extreme example of very weak system terminals connected by two parallel low impedance transmission branches, the true maximum power transfer limit is 50% lower than it would be if the external system was not considered at all. However, if we assumed infinite system strength at each terminal corresponding to equivalent source impedance magnitudes of zero, the maximum power transfer limit of the line with the external system ignored would be the same as the maximum power transfer limit calculated with consideration of the external system. Thus, for situations where the systems are strong at each of the line terminals and the line impedance is high (i.e., the transmission line is long and interconnects together two distant but strong systems), calculation of the maximum power transfer limit of the branch without consideration of the external system is a good approximation of the true maximum power transfer limit of the line (though not a worst-case approximation).

Figure 27 below illustrates how  $MPTL_{\text{BranchSystem}}$  (the maximum power transfer limit of a branch when consideration is given to the external system) varies as a percentage of  $MPTL_{\text{Branch}}$  (the maximum power transfer limit of a branch when the external system is ignored) for equivalent system impedances at Bus A and Bus B that vary from 0% to 50% of the reactive impedance of the branch in question. Plots are made assuming no parallel path to the branch (blue plot) and with a parallel equivalent branch (i.e., adjusted transfer impedance) with the same impedance as the branch in question (red plot).

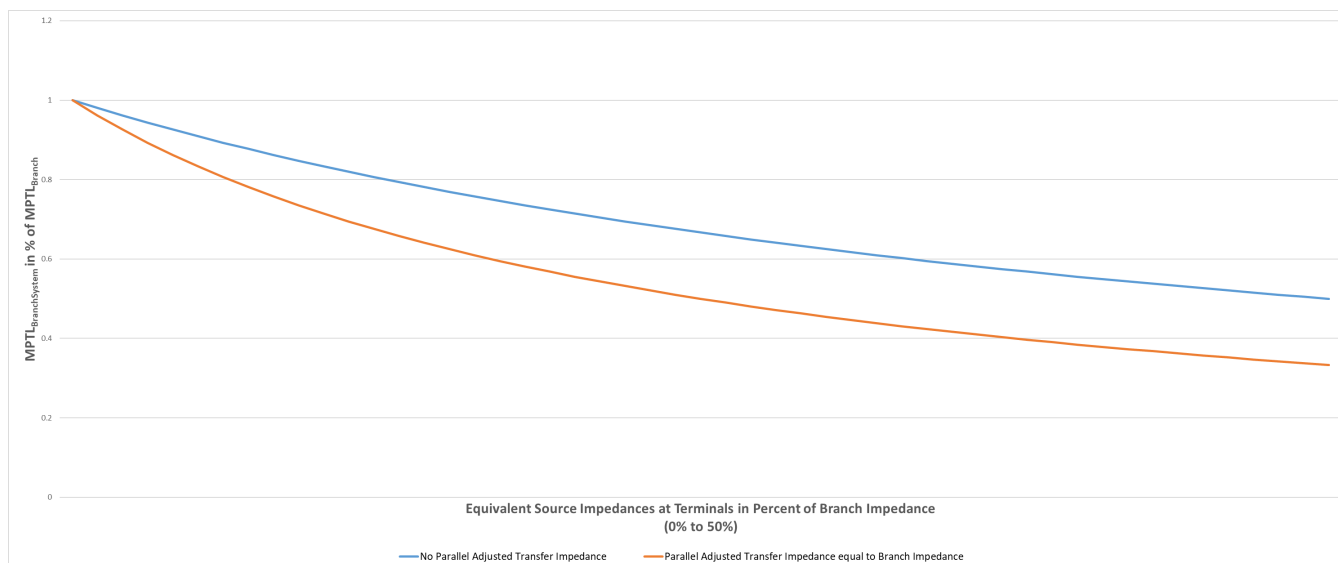

**Figure 27: Comparison of Maximum Power Transfer Limits in Per Unit with and without parallel transfer impedance equal to branch impedance**

Per Figure 27, the maximum power transfer limit of the branch with and without consideration of the external system are identical only when the equivalent system impedances are zero (infinite system strength at each terminal). An increase in the equivalent system impedances at each bus from 0% to 50% of the branch impedance in question will cause the true maximum power transfer level to decrease substantially. In cases where there is no parallel path between the buses, equivalent source impedances at each bus equal to 50% of the branch impedance would result in  $MPTL_{BranchSystem}$  (the maximum power transfer limit of the branch with the external system considered) to drop down to 50% of the  $MPTL_{Branch}$  (the maximum power transfer limit of the branch when the external system is ignored). Furthermore, assuming the branch is in parallel with an adjusted transfer impedance equal to the branch impedance, equivalent source impedances at each bus equal to 50% of the branch impedance would result in  $MPTL_{BranchSystem}$  (the maximum power transfer limit of the branch with the external system considered) to drop down to 33% of the  $MPTL_{Branch}$  (the maximum power transfer limit of the branch when the external system is ignored). In general, the extreme example above would not be an issue because it would only apply to short transmission lines between weak buses where the equivalent source reactive impedances could not be ignored relative to the transmission line reactance (points to the right in the graph above). In these situations, the thermal limits of the transmission line would likely be well below the true maximum power transfer limit of the transmission line since low branch impedances create very large branch maximum power transfer limits ( $MPTL_{Branch}$ ). However, in the paper titled “Analytical Development of Loadability Characteristics for EHV and UHV Transmission Lines”<sup>33</sup> written in 1979 by three AEP engineers, it was pointed out that system strength could be an issue for determining the angular loadability of 765 kV lines or UHV lines prior to full development of such systems, where the relative

<sup>33</sup> Dunlop, R.D., Gutman, R., Marchenko, P.P., *Analytical Development of Loadability Characteristics for EHV and UHV Transmission Lines*, IEEE Transactions on Power Apparatus and Systems, Vol. PAS-98, No. 2, March/April 1979.



strength of the terminals could be weak compared to the capacity and impedance of a 765 kV or UHV transmission line. In this particular paper, loadability was based on the line length (expressed in percent of SIL<sup>34</sup> for the voltage level in question) with the idea that longer lines would be limited by angular displacement rather than voltage drop, but given that the 765 kV system was not (and still is not) fully developed, the equivalent source impedances as viewed by the 765 kV system at the terminals of a 765 kV transmission line may not be negligible with regard to determining the loadability of even longer 765 kV lines, particularly if there are no other 765 kV line branches terminating at the terminal buses in question or the interconnecting facilities are otherwise weak relative to the 765 kV line. It is important to note that the equivalent model of the system external to a single transmission branch is not static, but changes with changes in resource commitment and/or transmission topology. So, any true maximum power transfer limit developed for a single branch (i.e.,  $MPTL_{BranchSystem}$ ) would be dynamic and would change as the external system changes. For this reason, it is generally not feasible to calculate a single true maximum power transfer limit for a transmission branch since it would be very dynamic and would thus change frequently as system conditions change. Instead, the issue of recognizing maximum power transfer limits is generally addressed by performing numerous system studies and simulations such as transient stability studies and/or small signal stability studies using detailed models of facilities and specific system conditions to guard against potential operation at or close to true maximum power transfer limits (which historically have been referred to as steady-state stability limits). In addition, steady-state stability margins are often applied to  $MPTL_{Branch}$  to determine a proxy for the true maximum power transfer limit ( $MPTL_{BranchSystem}$ ) expressed as a percentage of  $MPTL_{Branch}$ . The St. Clair curves discussed in the paper noted above (see footnote 6) were developed using a steady-state stability margin of 30% (which corresponds to an angular displacement between the sending-end and receiving-end voltages of the branch of just over 44°). While current industry practice typically does not establish maximum power transfer limits for individual branches, an alternative practice would be to calculate  $MPTL_{Branch}$  for each impedance branch (a straightforward calculation) and then apply a steady-state stability margin to determine a maximum power transfer screening limit ( $MPTL_{Screen}$ ). The screening limit would then be used as an input in determining the absolute limit. To the extent there are certain branches where this limit is lower than the thermal limits, additional analysis could be performed to determine, on a case-by-case basis, if the system would support a higher maximum power transfer limit, and if so, the absolute rating could be adjusted accordingly. The maximum power transfer screening limit would be calculated as follows:

$$MPTL_{Screen} = (1-SSSM) * MPTL_{Branch} = (1-SSSM) * |V_s||V_r| / |X_{Br}| \quad (5)$$

Where

$MPTL_{Screen}$  = Maximum Power Transfer Screening Limit in per unit

SSSM = Steady-state Stability Margin in per unit

Maximum Power Transfer Limit of HVDC Lines.

---

<sup>34</sup> SIL = Surge Impedance Loading and is the MW line loading where the reactive power consumed by the distributed series reactance of the line is equal to the reactive power produced by the distributed shunt capacitance of the line, thus there is not net injection or withdrawal of reactive power to or from the line.



Every HVDC line also has a maximum power transfer limit. While the reactance of an HVDC line does not impact steady state operation of the HVDC line, the conductor resistance does impact steady operation of the HVDC line. For power to be transferred in an HVDC line, DC current must flow in the HVDC line conductors. For current to flow in the HVDC line conductors, Ohm's law requires that a voltage difference exist between the sending end terminal and the receiving end terminal of the HVDC line. Assuming there are limits on DC voltage magnitude on an HVDC line of +/- 5% the maximum voltage drop across an HVDC line would be equal to the following:

$$\text{Maximum HVDC Line Voltage Drop} = 1.05 V_N - 0.95 V_N = 0.1 V_N \quad (6)$$

Where

$V_N$  = Nominal HVDC Line-to-Ground Voltage in kV or Per Unit

In this situation, the maximum current flow in an HVDC bi-pole line would be as follows:

$$\text{Maximum HVDC Current Flow} = 0.1 * V_N / R_L \quad (7)$$

Where

$R_L$  = Total resistance of HVDC line conductor in Ohms or per unit

Therefore, the maximum power transfer limit in MW or per unit for an HVDC bi-pole line with nominal voltage  $V_N$  and conductor resistance  $R_L$  would be as follows:

$$\text{Maximum HVDC Power Flow} = 2 * (1.05 * V_N) * (0.1 * V_N / R_L) = 0.21 * V_N^2 / R_L \quad (8)$$

---

**MISO thanks the National Lab of the Rockies (formerly National Renewable Energy Lab) for their contributions to this effort.**



The copyright in all material published in this report by the Midcontinent Independent System Operator, Inc. (MISO), including all portions of the content, design, text, graphics and the selection and arrangement of the material within the report (the “material”), is owned by MISO, or legally licensed to MISO, unless otherwise indicated. The material may not be reproduced or distributed, in whole or in part, without the prior written permission of MISO. Any reproduction or distribution, in whatever form and by whatever media, is expressly prohibited without the prior written consent of MISO.

© 2025 MISO. All rights reserved.